

DOCUMENTATION

**PUMP 40C260**

**AIRLESS**

**Manual : 582.007.110-UK - 2108**

*Date : 27/08/21*

*Supersede : 03/08/21*

*Modif.: Update*

**TRANSLATION FROM THE ORIGINAL MANUAL**

***IMPORTANT : Before assembly and start-up, please read and clearly understand all the documents relating to this equipment (professional use only).***

THE PICTURES AND DRAWINGS ARE NON CONTRACTUAL. WE RESERVE THE RIGHT TO MAKE CHANGES WITHOUT PRIOR NOTICE.

**SAMES KREMLIN SAS**

13, chemin de Malacher  
38 240 - MEYLAN - France

 : 33 (0)4 76 41 60 60

**[www.sames-kremlin.com](http://www.sames-kremlin.com)**



<p align="center"><b>FR</b></p> <p><b><u>Pour une utilisation sûre, il est de votre responsabilité de :</u></b></p> <ul style="list-style-type: none"> <li>• Lire attentivement tous les documents contenus dans le CD joint avant la mise en service de l'équipement,</li> <li>• D'installer, d'utiliser, d'entretenir et de réparer l'équipement conformément aux préconisations de SAMES KREMLIN ainsi qu'aux réglementations nationales et/ou locales,</li> <li>• Vous assurez que les utilisateurs de cet équipement ont été formés, ont parfaitement compris les règles de sécurité et qu'ils les appliquent.</li> </ul>	<p align="center"><b>UK</b></p> <p><b><u>To ensure safe use of the machinery, it is your responsibility to:</u></b></p> <ul style="list-style-type: none"> <li>• Carefully read all documents contained on the enclosed CD before putting the machinery into service,</li> <li>• Install, use, maintain and repair the machinery in accordance with SAMES KREMLIN's recommendations and national and/or local regulations,</li> <li>• Make sure that the users of the machinery have received proper training and that they have perfectly understood the safety rules and apply them.</li> </ul>	<p align="center"><b>DE</b></p> <p><b><u>Eine sichere Nutzung setzt voraus, dass Sie :</u></b></p> <ul style="list-style-type: none"> <li>• alle in der CD enthaltenen Dokumente vor der Inbetriebnahme der Anlage aufmerksam lesen,</li> <li>• die Anlage im Einklang mit den Empfehlungen von SAMES KREMLIN sowie mit den nationalen und/oder lokalen Bestimmungen installieren, verwenden, warten und reparieren,</li> <li>• sich vergewissern, dass die Nutzer dieser Anlage angemessen geschult wurden, die Sicherheitsbestimmungen verstanden haben und sie anwenden.</li> </ul>
<p align="center"><b>ES</b></p> <p><b><u>Para una utilización segura, será de su responsabilidad:</u></b></p> <ul style="list-style-type: none"> <li>• leer atentamente todos los documentos que se incluyen en el CD adjunto antes de la puesta en servicio del equipo,</li> <li>• instalar, utilizar, efectuar el mantenimiento y reparar el equipo con arreglo a las recomendaciones de SAMES KREMLIN y a la normativa nacional y/o local,</li> <li>• cerciorarse de que los usuarios de este equipo han recibido la formación necesaria, han entendido perfectamente las normas de seguridad y las aplican.</li> </ul>	<p align="center"><b>IT</b></p> <p><b><u>Per un uso sicuro, vi invitiamo a:</u></b></p> <ul style="list-style-type: none"> <li>• leggere attentamente tutta la documentazione contenuta nel CD allegato prima della messa in funzione dell'apparecchio,</li> <li>• installare, utilizzare, mantenere e riparare l'apparecchio rispettando le raccomandazioni di SAMES KREMLIN, nonché le normative nazionali e/o locali,</li> <li>• accertarvi che gli utilizzatori dell'apparecchio abbiano ricevuto adeguata formazione, abbiano perfettamente compreso le regole di sicurezza e le applichino.</li> </ul>	<p align="center"><b>PT</b></p> <p><b><u>Para uma utilização segura, é da sua responsabilidade:</u></b></p> <ul style="list-style-type: none"> <li>• Ler atentamente todos os documentos incluídos no CD em anexo antes de pôr o equipamento em funcionamento,</li> <li>• Proceder à instalação, utilização, manutenção e reparação do equipamento de acordo com as preconizações de SAMES KREMLIN, bem como com outros regulamentos nacionais e/ou locais aplicáveis,</li> <li>• Assegurar-se que os utilizadores do equipamento foram devidamente capacitados, compreenderam perfeitamente e aplicam as devidas regras de segurança.</li> </ul>
<p align="center"><b>NL</b></p> <p><b><u>Voor een veilig gebruik dient u:</u></b></p> <ul style="list-style-type: none"> <li>• alle document op de bijgevoegde cd aandachtig te lezen alvorens het apparaat in werking te stellen,</li> <li>• het apparaat te installeren, gebruiken, onderhouden en repareren volgens de door SAMES KREMLIN gegeven aanbevelingen en overeenkomstig de nationale en/of plaatselijke reglementeringen,</li> <li>• zeker te stellen dat de gebruikers van dit apparaat zijn opgeleid, de veiligheidsregels perfect hebben begrepen en dat zij die ook toepassen.</li> </ul>	<p align="center"><b>SE</b></p> <p><b><u>För en säker användning av utrustningen ansvarar ni för följande:</u></b></p> <ul style="list-style-type: none"> <li>• Läs noga samtliga dokument som finns på den medföljande cd-skivan innan utrustningen tas i drift.</li> <li>• Installera, använd, underhåll och reparera utrustningen enligt anvisningarna från SAMES KREMLIN och enligt nationella och/eller lokala bestämmelser.</li> <li>• Försäkra er om att användare av denna utrustning erhållit utbildning, till fullo förstått säkerhetsföreskrifterna och tillämpar dem.</li> </ul>	<p align="center"><b>FI</b></p> <p><b><u>Käytön turvallisuuden varmistamiseksi velvollisuutesi on:</u></b></p> <ul style="list-style-type: none"> <li>• Lukea huolella kaikki CD:llä olevat asiakirjat ennen laitteiston käyttöönottoa,</li> <li>• Noudata laitteiston asennuksessa, käytössä, kunnossapidossa ja huollossa SAMES KREMLIN in suosituksia sekä kansallisia ja/tai paikallisia määräyksiä,</li> <li>• Varmistaa, että laitteiston käyttäjät ovat koulutettuja ja ymmärtävät täysin turvallisuusmääräykset ja miten niitä sovelletaan.</li> </ul>
<p align="center"><b>PL</b></p> <p><b><u>Dla zapewnienia bezpiecznego użytkowania na użytkownika spoczywa obowiązek:</u></b></p> <ul style="list-style-type: none"> <li>• Uważnie zapoznać się ze wszystkimi dokumentami znajdującymi się na załączonej płycie CD przed pierwszym uruchomieniem urządzenia,</li> <li>• Instalowanie, użytkowanie, konserwacji i naprawy urządzenia zgodnie z zaleceniami firmy SAMES KREMLIN oraz z przepisami miejscowymi,</li> <li>• Upewnienia, że wszyscy przeszkoleni użytkownicy urządzenia zrozumieli zasady bezpieczeństwa i stosują się do nich.</li> </ul>	<p align="center"><b>CS</b></p> <p><b><u>Pro bezpečné používání jste povinni:</u></b></p> <ul style="list-style-type: none"> <li>• Před uvedením zařízení do provozu si pozorně přečíst veškeré dokumenty obsažené na příloženém CD,</li> <li>• Nainstalovat, používat, udržovat a opravovat zařízení v souladu s pokyny firmy SAMES KREMLIN a s národními a/nebo místními legislativními předpisy,</li> <li>• Ujistit se, že uživatelé tohoto zařízení byli vyškoleni, že dokonale pochopili bezpečnostní pravidla a že je dodržují.</li> </ul>	<p align="center"><b>SL</b></p> <p><b><u>Za varno uporabo ste dolžni:</u></b></p> <ul style="list-style-type: none"> <li>• natančno prebrati vse dokumente na CD pred zagonom stroja,</li> <li>• inštalirati, uporabljati, vzdrževati in popravljati opremo po določilih SAMES KREMLIN in v skladu z veljavnimi nacionalnimi in/ali lokalnimi predpisi,</li> <li>• poskrbeti, da so uporabniki te opreme ustrezno usposobljeni, poznajo varnostne predpise in da jih upoštevajo.</li> </ul>
<p align="center"><b>SK</b></p> <p><b><u>V záujme bezpečného je vašou povinnosťou:</u></b></p> <ul style="list-style-type: none"> <li>• pozorne si prečítať všetky dokumenty obsiahnuté na priloženom CD predtým, ako zariadenie uvediete do prevádzky,</li> <li>• nainštalovať, používať, udržiavať a opravovať zariadenie v súlade s odporúčaniami spoločnosti SAMES KREMLIN a národnými a/alebo miestnymi predpismi,</li> <li>• uistiť sa, že používatelia tohto zariadenia boli zaškolení, riadne porozumeli pravidlám bezpečnosti a používajú ich.</li> </ul>	<p align="center"><b>HU</b></p> <p><b><u>A biztonságos használat érdekében az Ön felelőssége, hogy:</u></b></p> <ul style="list-style-type: none"> <li>• a berendezés üzembe helyezése előtt figyelmesen elolvassa a mellékelt CD által tartalmazott összes dokumentumot,</li> <li>• a berendezést a SAMES KREMLIN ajánlásainak valamint a nemzeti és/vagy helyi szabályozásoknak megfelelően helyezze üzembe, használja, tartsa karban és javítsa,</li> <li>• megbizonyosodjon róla, hogy a berendezés felhasználói képzettek, tökéletesen megértették és alkalmazzák a biztonsági előírásokat.</li> </ul>	<p align="center"><b>RO</b></p> <p><b><u>Pentru o utilizare sigură, este responsabilitatea dvs. să:</u></b></p> <ul style="list-style-type: none"> <li>• Citiți cu atenție toate documentele de pe CD-ul anexat, înainte de punerea în funcțiune a echipamentului,</li> <li>• Instalați, utilizați, întrețineți și reparați echipamentul conform instrucțiunilor SAMES KREMLIN precum și reglementărilor naționale și/sau locale,</li> <li>• Vă asigurați că utilizatorii acestei echipament au fost instruiți, au înțeles perfect regulile de securitate și le aplică integral.</li> </ul>

Declaration(s) de conformité au verso de ce document / Declaration(s) of conformity at the back of this document / Konformitätserklärung(en) auf der Rückseite dieser Unterlage / Declaración (es) de conformidad en el reverso de este documento / Dichiarazione/i di conformità sul retro del presente documento / Declaração(ões) de conformidade no verso do documento / Conformiteitsverklaring(en) op de keerzijde van dit document / Försäkran om överensstämmelse på omstående sida av detta dokument / Vaatimustenmukaisuusvakuutukset tämän asiakirjan kääntöpuolella / Deklaracja(e) zgodności na odwrocie dokumentu / Prohlášení o shodě se nachází/nacházejí na zadní straně tohoto dokumentu / Deklaracija(e) o skladnosti na hrbni strani tega dokumenta / Vyhlášení/-a o zhode sa nachádzajú na zadnej strane dokumentu / A dokumentum hátlapján szereplő megfelelőségi nyilatkoz(ok) / Declarații de conformitate pe versoul acestui document



**DECLARATION UE DE CONFORMITE**  
**EU DECLARATION OF CONFORMITY**  
**EU- KONFORMITÄTSERKLÄRUNG**  
**DECLARACIÓN UE DE CONFORMIDAD**  
**DICHIARAZIONE DI CONFORMITÀ UE**  
**DECLARAÇÃO UE DE CONFORMIDADE**  
**EU-CONFORMITEITSVERKLARING**  
**EU-FÖRSÄKRAN OM ÖVERENSSTÄMMELSE**  
**EU- VAATIMUKSEN MUKAISUUSVAKUUTUS**  
**DEKLARACJA ZGODNOŚCI UE**  
**EU PROHLÁŠENÍ O SHODĚ**  
**IZJAVA EU O SKLADNOSTI**  
**VYHLÁSENIE O ZHODE**  
**EU-MEGFELELŐSÉGI NYILATKOZAT**  
**DECLARAȚIA DE CONFORMITATE UE**

Le fabricant / The manufacturer / Der Hersteller / El fabricante / Il produttore / O fabricante / De fabrikant / Tillverkare / Valmistaja / Producent / Výrobce / Proizvajalec / Výrobca / Gyártó / Fabricantul:	<b>SAMES KREMLIN SAS</b> 13, chemin de Malacher 38 240 - MEYLAN - FRANCE Tél. : 33 (0)4 76 41 60 60
---	--

Déclare que le matériel désigné ci-après / Herewith declares that the equipment / erklårt hiermit, dass die / Declara que el material designado a continuación / Dichiaro che il materiale sottoindicato / Declara que o material a seguir designado / verklaart dat de hieronder aangeduide apparatuur / Kungör att den utrustning som anges här nedan / ilmoittaa, että alla mainitut laitteistot / Oświadcza, że wymienione poniżej urządzenia / Prohlašuje, že níže uvedené vybavení / Izjavlja, da je opisana oprema spodaj / Vyhlásuje, že zariadenie uvedené nižšie / Kijelenti, hogy a megjelölt anyag a továbbiakban / Declară că echipamentul precizat mai jos:

**POMPES AIRLESS® / AIRLESS PUMPS / AIRLESS PUMPE / BOMBAS AIRLESS**

40C100	40C100 WB
--------	-----------

Est conforme à la législation d'harmonisation de l'Union applicable suivante / Is in conformity with the relevant Union harmonisation legislation / Erfüllt die einschlägigen Harmonisierungsrechtsvorschriften der Union / es conforme con la legislación de armonización pertinente de la Unión / è conforme alla pertinente normativa di armonizzazione dell'Unione / in overeenstemming met de desbetteffende harmonisatiewetgeving van de Unie / med den relevanta harmoniserade unionslagstiftningen / on asiaa koskevan unionin yhdenmukaistamislainsäädännön vaatimusten mukainen / jest zgodny z odnośnymi wymaganiami unijnego prawodawstwa harmonizacyjnego / Shoduje se s následující příslušnou evropskou harmonizační legislativou / V skladu s harmonizirano zakonodajo Unije / Je v súlade s uplatniteľnými harmonizačnými právnymi predpismi EÚ / Megfelel a következõ alkalmazandó uniós harmonizációs szabályozásnak / Este conform cu legislația aplicabilă de armonizare de mai jos

Directive ATEX / ATEX Directive / ATEX Richtlinie / Directiva ATEX / Direttiva ATEX / Diretiva ATEX / ATEX-Richtlijn / ATEX-direktivet / ATEX-direktivi / Dyrektywa ATEX / Směrnice ATEX / Direktiva ATEX / Smernica ATEX / ATEX-irányelv		<b>2014/34/UE</b>
---	--	-------------------

40C50	40C50 WB
-------	----------

Est conforme à la législation d'harmonisation de l'Union applicable suivante / Is in conformity with the relevant Union harmonisation legislation / Erfüllt die einschlägigen Harmonisierungsrechtsvorschriften der Union / es conforme con la legislación de armonización pertinente de la Unión / è conforme alla pertinente normativa di armonizzazione dell'Unione / in overeenstemming met de desbetteffende harmonisatiewetgeving van de Unie / med den relevanta harmoniserade unionslagstiftningen / on asiaa koskevan unionin yhdenmukaistamislainsäädännön vaatimusten mukainen / jest zgodny z odnośnymi wymaganiami unijnego prawodawstwa harmonizacyjnego / Shoduje se s následující příslušnou evropskou harmonizační legislativou / V skladu s harmonizirano zakonodajo Unije / Je v súlade s uplatniteľnými harmonizačnými právnymi predpismi EÚ / Megfelel a következõ alkalmazandó uniós harmonizációs szabályozásnak / Este conform cu legislația aplicabilă de armonizare de mai jos

Directive ATEX / ATEX Directive / ATEX Richtlinie / Directiva ATEX / Direttiva ATEX / Diretiva ATEX / ATEX-Richtlijn / ATEX-direktivet / ATEX-direktivi / Dyrektywa ATEX / Směrnice ATEX / Direktiva ATEX / Smernica ATEX / ATEX-irányelv		<b>2014/34/UE</b>
---	--	-------------------

40C260	40C260_2
65C260	65C260_2

Est conforme à la législation d'harmonisation de l'Union applicable suivante / Is in conformity with the relevant Union harmonisation legislation / Erfüllt die einschlägigen Harmonisierungsrechtsvorschriften der Union / es conforme con la legislación de armonización pertinente de la Unión / è conforme alla pertinente normativa di armonizzazione dell'Unione / in overeenstemming met de desbetteffende harmonisatiewetgeving van de Unie / med den relevanta harmoniserade unionslagstiftningen / on asiaa koskevan unionin yhdenmukaistamislaainsäädännön vaatimusten mukainen / jest zgodny z odnośnymi wymaganiami unijnego prawodawstwa harmonizacyjnego / Shoduje se s následující příslušnou evropskou harmonizační legislativou / V skladu s harmonizirano zakonodajo Unije / Je v súlade s uplatniteľnými harmonizačnými právnymi predpismi EÚ / Megfelel a következö alkalmazandó uniós harmonizációs szabályozásnak / Este conform cu legislația aplicabilă de armonizare de mai jos

Directive ATEX / ATEX Directive / ATEX Richtlinie / Directiva ATEX / Direttiva ATEX / Diretiva ATEX / ATEX-Richtlijn / ATEX-direktivet / ATEX-direktivi / Dyrektywa ATEX / Směrnice ATEX / Direktiva ATEX / Smernica ATEX / ATEX-irányelv		<b>2014/34/UE</b>
---	---	-------------------

La présente déclaration de conformité est établie sous la seule responsabilité du fabricant / This declaration of conformity is issued under the sole responsibility of the manufacturer / Die alleinige Verantwortung für die Ausstellung dieser Konformitätserklärung trägt der Hersteller / La presente declaración de conformidad se expide bajo la exclusiva responsabilidad del fabricante / La presente dichiarazione di conformità è rilasciata sotto la responsabilità esclusiva del fabbricante / A presente declaração de conformidade é emitida sob a exclusiva responsabilidade do fabricante / Deze conformiteitsverklaring wordt verstrekt onder volledige verantwoordelijkheid van de fabrikant / Denna försäkran om överensstämmelse utfärdas på tillverkarens eget ansvar / Tämä vaatimustenmukaisuusvakuutus on annettu valmistajan yksinomaisella vastuulla / Niniejsza deklaracja zgodności wydana zostaje na wyłączną odpowiedzialność producenta / Toto prohlášení o shodě se vydává na výhradní odpovědnost výrobce / Za izdajo te izjave o skladnosti je odgovoren izključno proizvajalec / Toto vyhlásenie o zhode sa vydáva / na vlastnú zodpovednosť výrobcu / Ezt a megfelelőségi nyilatkozatot a gyártó kizárólagos felelőssége mellett adják ti / Prezenta declarație de conformitate este emisă pe răspunderea exclusivă a producătorului.



Hervé WALTER

Directeur Innovation & Développement / Innovation & Development Director / Direktor für Innovation & Entwicklung / Director de Innovación y Desarrollo / Direttore Innovazione e sviluppo / Diretor de Inovação / Manager Innovatie en Ontwikkeling / Direktör för Forskning och Utveckling / Innovaatio- ja kehitysjohtaja / Dyrektor ds. Innowacji i Rozwoju / Ředitel pro inovace a vývoj / Direktor za inovacije in razvoj / Riaditeľ pre inováciu a rozvoj / Innovációs és fejlesztési igazgató / Director Inovație și Dezvoltare

Fait à Meylan, le / Established in Meylan, on / Geschehen zu Meylan, am / En Meylan, a / Redatto a Meylan, / Vastgesteld te Meylan, / Utformat i Meylan, den / Meylan, Ranska, / Sporządzono w Meylan, dnia / Meylan, dnia / V Meylanu, / V Meylan dňa / Kelt Meylanban, / Întocmită la Meylan, pe data de 31/01/2019 - 01/31/2019



# INSTALLATION AND SAFETY INSTRUCTIONS

## TRANSLATION FROM THE ORIGINAL MANUAL

***IMPORTANT*** : Before assembly and start-up, please read and clearly understand all the documents relating to this equipment (professional use only).

THE PICTURES AND DRAWINGS ARE NON CONTRACTUAL. WE RESERVE THE RIGHT TO MAKE CHANGES WITHOUT PRIOR NOTICE.

**SAMES KREMLIN SAS**  
13, chemin de Malacher  
38 240 - MEYLAN - France  
☎ : 33 (0)4 76 41 60 60

**[www.sames-kremlin.com](http://www.sames-kremlin.com)**

# 1. SAFETY INSTRUCTIONS

## GENERAL SAFETY INSTRUCTIONS



**CAUTION :** The equipment can be dangerous if you do not follow our instructions concerning installation and servicing described in this manual and in accordance with applicable European standards and local national safety regulations.

Please carefully read all the instruction literature before operating your equipment.

### **Only trained operators can use the equipment.**

The foreman must ensure that the operator has understood the safety instructions for this equipment as well as the instructions in the manuals for the different parts and accessories.

Read carefully all instruction manuals, label markings before operating the equipment.

Incorrect use may result in injury. This equipment is for professional use only. It must be used only for what it has been designed for. Never modify the equipment. The parts and accessories supplied must be regularly inspected. Defective or worn parts must be replaced.







**Guards (motor cover, coupling shields, connectors,...) have been designed for a safe use of the equipment.**

**The manufacturer will not be held responsible for bodily injury or failure and / or property damage due to destruction, the overshadowing or the partial or total removal of the guards.**

### **Never exceed the equipment components' maximum working pressure.**

Comply with regulations concerning safety, fire risks, electrical regulations in force in the country of final destination of the material. Use only products or solvent compatible with the parts in contact with the material (refer to data sheet of the material manufacturer).

## PICTOGRAMS

					
NIP HAZARD	WARNING MOVING ELEVATOR	WARNING MOVING PARTS	WARNING MOVING SHOVEL	DO NOT EXCEED THIS PRESSURE	HIGH PRESSURE HAZARD
					
RELIEF OR DRAIN VALVE	WARNING HOSE UNDER PRESSURE	WEAR GLASSES OBLIGATORY	WEAR OF GLOVES IS OBLIGATORY	PRODUCT VAPOR HAZARDS	WARNING HOT PARTS OR AREAS
					
ELECTRICAL HAZARD	WARNING FIRE HAZARDS	EXPLOSION HAZARDS	GROUNDING	WARNING (USER)	WARNING SERIOUS INJURIES

## PRESSURE HAZARDS



Current legislation requires that an **air relief valve** be fitted in the air supply circuit to the air motor to prevent over pressurisation. This safety feature, ensures that it is not possible to supply the air motor with excessive air pressure that may cause injury.

Please ensure that a **material drain valve** is fitted in the fluid circuit to drain and depressurise the circuit. Once depressurised and drained, work /servicing may then commence on the equipment. Please remember to close these valves when restarting the system.

## HIGH PRESSURE INJECTION HAZARDS



When working with high pressure equipment, special care is required. Fluid leaks can occur. There is a risk of material being injected to any exposed parts of body, this could cause severe injury :



- medical care must be sought immediately if paint is injected under the skin or in other parts of the body (eyes, fingers).
- never point the spray gun at any one. Never try to stop the spray with your hands or fingers nor with rags or similars.
- **follow the shut down procedure and always depressurize air and fluid circuits** before carrying out any servicing on the gun (cleaning, checking, maintenance of the material or cleaning of the gun nozzles).
- for the guns equipped with a safety device, always lock the trigger when not in use.

## FIRE - EXPLOSION - SPARKS - STATIC ELECTRICITY HAZARDS



A poor earth connection, inadequate ventilation, sparks or static electricity can cause an explosion or fire. to avoid these risks when using or servicing SAMES KREMLIN equipment, the following safety procedures must be followed :



- ensure a good earth connection and ground the parts to be handled i.e. solvents, materials, components and equipment,
- ensure adequate ventilation,
- keep working area clean and free from waste solvents, chemicals, or solid waste i.e. rags, paper and empty chemicals drums,
- never use electrical switches / power if in an atmosphere of volatile solvent vapour,
- stop working immediately in case of electrical arcs,
- never store chemicals and solvents in the working area.
- use paint whose flash point is the highest possible to prevent from any formation of gas and inflammable vapours (refer to materials' safety instructions),
- install a cover on the drums to reduce the diffusion of gas and vapours in the spraybooth.

## TOXIC PRODUCT HAZARDS



Toxic products or vapours can cause severe injury not only though contact with the body, but also if the products are ingested or inhaled. It is imperative :



- to know the material products and their risks,
- notified or hazardous materials must be stored in accordance with the regulations,
- the material must be stored in an appropriate container, never place materials in a container where there is a risk of spillage or leakage,
- a procedure must be applied for the safe disposal of waste material. It must comply with all prevailing regulations and legislations of the country where the equipment is to be used,
- protective clothing should always be worn in compliance with the material manufacturers' recommendations,
- depending on the application and chemical safety instructions, safety glasses, hearing protective earplug, gloves, foot wear, protective masks and possible breathing equipment should be worn to comply with the regulations (Refer to chapter "Safety equipment of SAMES KREMLIN selection guide).



### CAUTION!

It is forbidden to use material containing high concentrations of halogenated hydrocarbon solvents with **aluminium** or **zinc fillers**. Non-compliance with the instructions may cause explosion risk causing serious or fatal injury.



### EQUIPMENT REQUIREMENTS

**Guards (motor cover, coupling shields, connectors,...) have been designed for a safe use of the equipment.**

**The manufacturer will not be held responsible for bodily injury or failure and / or property damage due to destruction, the overshadowing or the partial or total removal of the guards.**

### PUMP



Before carrying out any work, it is imperative to read and clearly understand the disassembly and reassembly instructions before servicing. The operator must understand the equipment and the safety instructions. These instructions are available in the equipment manuals.



The air motor is designed to be mounted with a pump. Never modify any components or couplings. When operating, please keep hands away from moving parts. Before starting up the equipment, please read the PRESSURE RELIEF instructions. Please ensure that any relief or drain valves fitted are in good working order.

### HOSES

- Keep hoses out of circulation areas, moving parts or hot surfaces,
- Never expose product hoses to temperature higher than + 60°C / 140° F or lower than 0°C / 32° F,
- Never pull or use the hoses to move the equipment,
- Tighten all fittings as well as the hoses before operating the equipment,
- Check the hoses regularly; change them if they are damaged,
- Never exceed the maximum working pressure (MWP) indicated on the hose.

### USED PRODUCTS

Considering the wide variety of products that are available and can be used in our equipment it is impossible to check and make recommendations for all chemical data, regarding the risks of possible chemical attack and their long term chemical reaction

SAMES KREMLIN can not be held liable for :

- compatibility of wetted parts,
- risks to staff and the surroundings,
- for worn or defective parts, for faulty equipment or units, or the quality of final product.

It is the responsibility of the user to know and prevent any possible risks such as toxic vapours, fires or explosions. He shall determine the risks of immediate reactions or pursuant to repeated exposures of the staff,

SAMES KREMLIN shall not be liable for physical injuries, direct or indirect material damages caused by the use of chemicals.

## 2. HANDLING



### **Check the weight and the dimensions of the equipment**

**(☞ refer to 'Technical features' section of the instruction manual**

If weight and dimensions are too important, the unloading must be carried out by means of a forklift or any other appropriate means with a qualified personnel and in a clear horizontal area to prevent from risks of damage injury or an accident.

The centre of gravity is not in the centre of the machine : carry out by hand a stability-test after having lifted the whole at 10 cm / 3.937" maximum.

After the unloading, the handling of the whole (eg: elevator pump) is carried out by means of a pallet truck taking the bottom part of the frame.

**Remark : Each pump motor is fitted with a ring. The ring is designed for the hoisting of one pump and can not be used for the handling of the complete assembly.**

## 3. STORING

Storing before installation :

- Storing ambient temperature : 0 / +50 °C / 0 / +122°F
- Protect the whole against dust, water trickling, dampness and shocks.

Storing after installation :

- Operating temperature : +15 / +35 °C / +59 / +138.2° F
- Protect the whole against dust, water trickling, dampness and shocks.

## 4. INSTALLATION OF THE EQUIPMENT

The machine is installed on a stable horizontal floor (for eg a concrete flag).

The machine shall be made stable by the use of holding down bolts or by the use of other anchoring methods, strong enough to prevent unintended bodily movement of the equipment.



**To avoid risks caused by static electricity, the equipment as well as its components must be grounded.**

- **For the pumping equipments** (pumps, pneumatic rams, frame...), a section wire of 2.5 mm<sup>2</sup> is fixed on the material. Use this wire to connect the material to "the general ground". In case of severe environments (mechanical protection of the wire of earthing insufficient, vibrations, mobile material...) where function damages at the ground are probable, the user have to replace the provided wire of 2.5 mm<sup>2</sup> by a device more adapted to its environment (wire with a more important section, bonding strip, fixing by thimble with eyelet...).

The continuity of the ground must be controlled by a qualified electrician. If the continuity of the ground is not ensured, check the terminal, the wire and the earthing point. **Never** use the material without have solved this problem.

- In the severe cases of environments (mechanical protection of the wire of earthing insufficient, vibrations, mobile material...) where damages of the function put at the ground are probable, the user will have to replace the wire of 2.5 mm<sup>2</sup> provided, by a device more adapted to its environment (wire of more important section, bonding strip, fixing by thimble with eyelet...),
- **The gun** must be 'grounded' via a material hose or an air hose. In case of spraying by means of a gun with cup, the air hose must be conductive,
- **The materials to be painted** must also be grounded.

**All the materials situated in the working area shall be grounded.**



- **Never store** more than necessary inflammable materials inside the working area,
- The materials must be stored into **approved drums** and grounded,
- Use only grounded **metals containers** for the use of cleaning solvents,
- **Cardboard and paper are prohibited.**

## 5. MARKING OF THE EQUIPMENT



Each equipment has a label plate with the name of the manufacturer, the equipment part number, the interesting informations to use correctly the equipment (pressure, voltage,...) and sometimes the above pictogram.

The equipment is designed with and consists of high quality materials and components which can be re-used.

The 2012/19/UE European Directive covers all equipments with a crossed-out bin pictogram. Please inform yourself about the collection systems for electric and electronic equipments.

Please act in accordance with local rules and **do not dispose of old equipment with household wastes**. A correct disposal of old equipment will help prevent negative consequences for the environment and health.

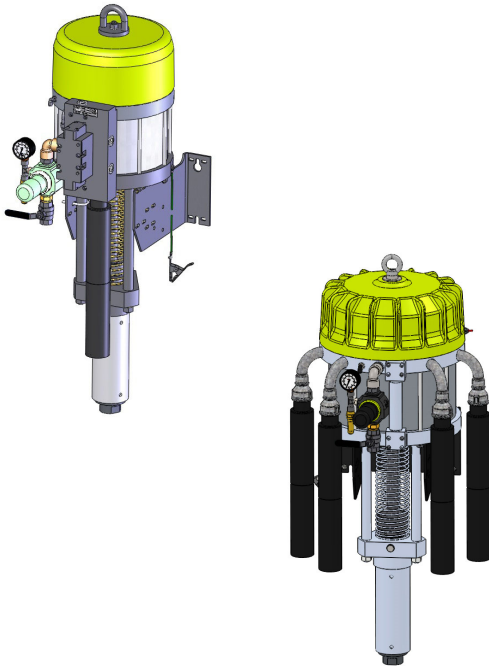

## AIRLESS PUMPS

**40C260**

**65C260**

***Disassembly / Reassembly***

### TRANSLATION FROM THE ORIGINAL MANUAL

***IMPORTANT : Before assembly and start-up, please read and clearly understand all the documents relating to the equipment (professional use only).***

THE PICTURES AND DRAWINGS ARE NOT CONTRACTUAL. WE RESERVE THE RIGHT TO MAKE CHANGES WITHOUT PRIOR NOTICE.

**SAMES KREMLIN SAS**  
13, chemin de Malacher  
38 240 - MEYLAN - France  
☎ : 33 (0)4 76 41 60 60

**[www.sames-kremlin.com](http://www.sames-kremlin.com)**



---

---

**CAUTION :**

**Before any action on the pump, shut off the compressed air supply and depressurize the system.**

---

---

**The pump is manufactured under the ATEX agreement and can not be modified. SAMES KREMLIN will not be held responsible for any failure to comply with that instruction.**

▪ **FLUID MOTOR OR AIR MOTOR REPLACEMENT (REFER TO DOC. 573.412.050 & 573.413.050)**

**Guards (air motor cover, coupling shields, housings ...) have been designed for safe use of the equipment.**

**The manufacturer will not be held responsible for bodily injury or failure and / or damage to property due to removal or partial removal of the guards.**

Position the air motor piston in a high position before shutting off the compressed air and before depressurizing the system.

Disassemble all the accessories of the pump (rods, filter).

Disassemble the pump from the cart, then from the bracket by removing the nuts that hold on the U-bolts.

Put aside the pump (the pump is fitted with an hoisting ring).

Remove the 3 nuts (4) that hold on the 3 tie-rods (3).

Disassemble the air motor from the fluid section by removing the coupling rod from the air motor and the piston from the air motor (hold on the coupling rod and unscrew the piston by means of a wrench).

**When changing the fluid section :**

Position the spring protection on the new fluid section piston, assemble the air motor and the fluid section, the tie-rods and the nuts.

Position the whole on the wall mounted unit.

**When changing the air motor :**

Remove the air supply from the old air motor and assemble it on the new one.

Assemble the new air motor and the fluid section (as it is specified previously).

Fix the pump on its bracket.

## DISASSEMBLY / REASSEMBLY OF THE FLUID SECTION

**Guards (air motor cover, coupling shields, housings ...) have been designed for safe use of the equipment.**

**The manufacturer will not be held responsible for bodily injury or failure and / or damage to property due to removal or partial removal of the guards.**

### ▪ SUCTION VALVE (15)

#### Disassembly

Unscrew the suction valve (16). (If the cylinder (2) remains attached to the suction valve, unscrew both parts, then hold cylinder (2) by inserting a rod into the cylinder holes designed for this purpose).

The ball (17) is secured on the valve (16) by means of a circlips (18).

Clean the parts with the appropriate cleaning solvent.

#### Reassembly

Reinstall the ball (17) and the circlips (18) on the valve body (16).

Change the seal (19). Lubricate it.

 Lubricate the valve body threading.

Reinstall the valve assembly (15) on the cylinder (2).

### ▪ CYLINDER (2)

In order to make easier the disassembly, a hole is made in the cylinder (2) at each end.

Depending on the part that it is unscrewed first, insert a rod into one of these holes to unscrew the other part.

When reassembling, make sure the two seals (19 and 25) are installed. Lubricate them.

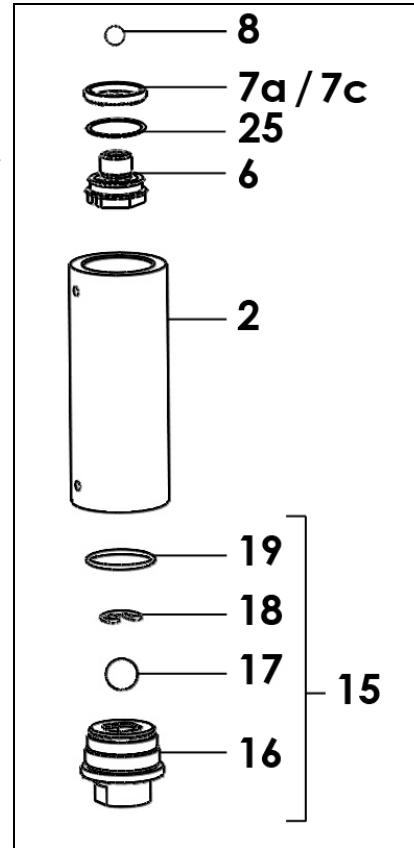

 Lubricate the inside of the cylinder (grease, type A1) and the threadings to prevent from damaging the mobile packing (grease, type A2) (Refer to greases in the Assembly instructions §).

### ▪ EXHAUST VALVE (6) AND MOBILE PACKING (7)

#### Disassembly

Unscrew the cylinder (2) and pull it downwards.

Unscrew the exhaust valve (6) with a flat wrench n° 46 by holding the piston (3).

Remove the ball (8), the mobile packing (seal - 7a/7c).

Clean the parts.

#### Reassembly

Install a new seal (7a/7c). Lubricate it.

➤ **Comply with the seal installation order.**

Install the ball (8) on the exhaust valve (6).

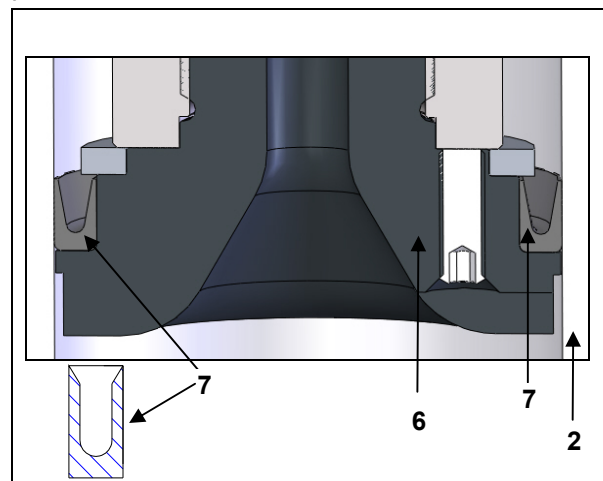

 Lubricate the threading of the exhaust valve (grease, type A2).

Tighten the whole in the piston lower part (3).

▪ **UPPER PACKING (9)**

**Disassembly**

Disassemble the coupling rod from the air motor and the piston (3) from the fluid section.

Unscrew the wetting-cup (4) by means of the wrench provided with the pump.

Unscrew the cylinder (2) and pull the piston (3) downwards. Pull the upper packing (9) upwards and remove the seals (10 and 11).

**Reassembly**

 Change the seals (10 & 11) and lubricate them.

On the support washer (12), install the seals (10 & 11) (**comply with orientation and order**) as well as the blocking washer (13) {→ upper packing (9)}.

**You must install a seal (11), then another one (10) according to the opposite drawing.** The first seal in contact with the material must be the stiffer one.

 Grease the cone shaped tool (the tool is supplied with the fluid section).

Position the upper packing (9) on the tool (53).

Slide the piston (3) into the flange (1) by inserting it from bottom to top.

Position the tool equipped with the seals on the upper part of the piston.

Slide the seals on the piston. The tool prevents from damaging the seals when assembling the piston.

Remove the tool.

Position the seals (always set up on the piston) into the upper flange (1).

 **Hold the piston to prevent from its sliding downwards.**

Tighten by hand the wetting-cup (4) without tightening the upper flange (1).

**After reassembling, fill up the pump with solvent and increase progressively the pressure to maximum → setting up of the seals.**

**After half an hour, stop the pump and open the exhaust valve to depressurize.**

**Retighten the wetting-cup (4) by means of the wrench supplied with the pump in order to be in accordance with the drawing. Comply with assembly dimension.**

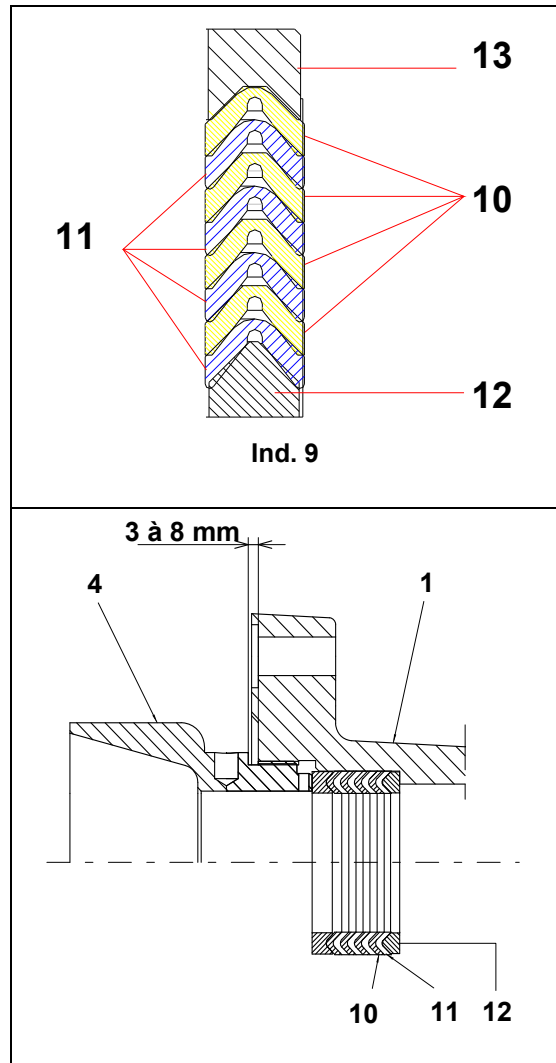

**Before reassembling the different components :**

- **Clean the parts with the appropriate cleaning solvent.**
- **Install the new seals if it is necessary after having lubricated them with PTFE grease.**
- **Lubricate the piston and the inside of the cylinder to prevent from damaging the seals.**
- **Install new parts if it is necessary.**

## AIR MOTOR

### ■ AIR MOTOR REVERSING BLOCK (REFER TO DOC. 573.087.040)

**Guards (air motor cover, coupling shields, housings ...) have been designed for safe use of the equipment.  
The manufacturer will not be held responsible for bodily injury or failure and / or damage to property due to removal or partial removal of the guards**

Disassemble the air motor cover (6 or 31) by removing the nut (4 or 33).

Dissociate the female yoke from the reversing block lever (9a / 9b).

Dismount the reversing-block by removing the screws (11 or 28).

Remount the new reversing-block in the reverse order of the disassembly sequence.

⚠ **CAUTION** : the number of spirals must equally be distributed on each fastening parts in order to get the above dimension.

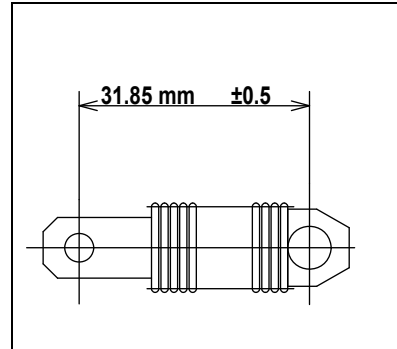

### ■ DEGREES OF WEAR

The wetted parts in contact with the material are subject to wear with time. It depends, of course, on the rates and duration of pump operating; also on the material handled.

Under normal operating and servicing conditions, with standard filled material not including foreign matters or chemically aggressive, the average working life can be estimated as :

- **1 million strokes for the tightness seals.**
- **10 millions strokes for the bellows.**

# ASSEMBLY INSTRUCTIONS

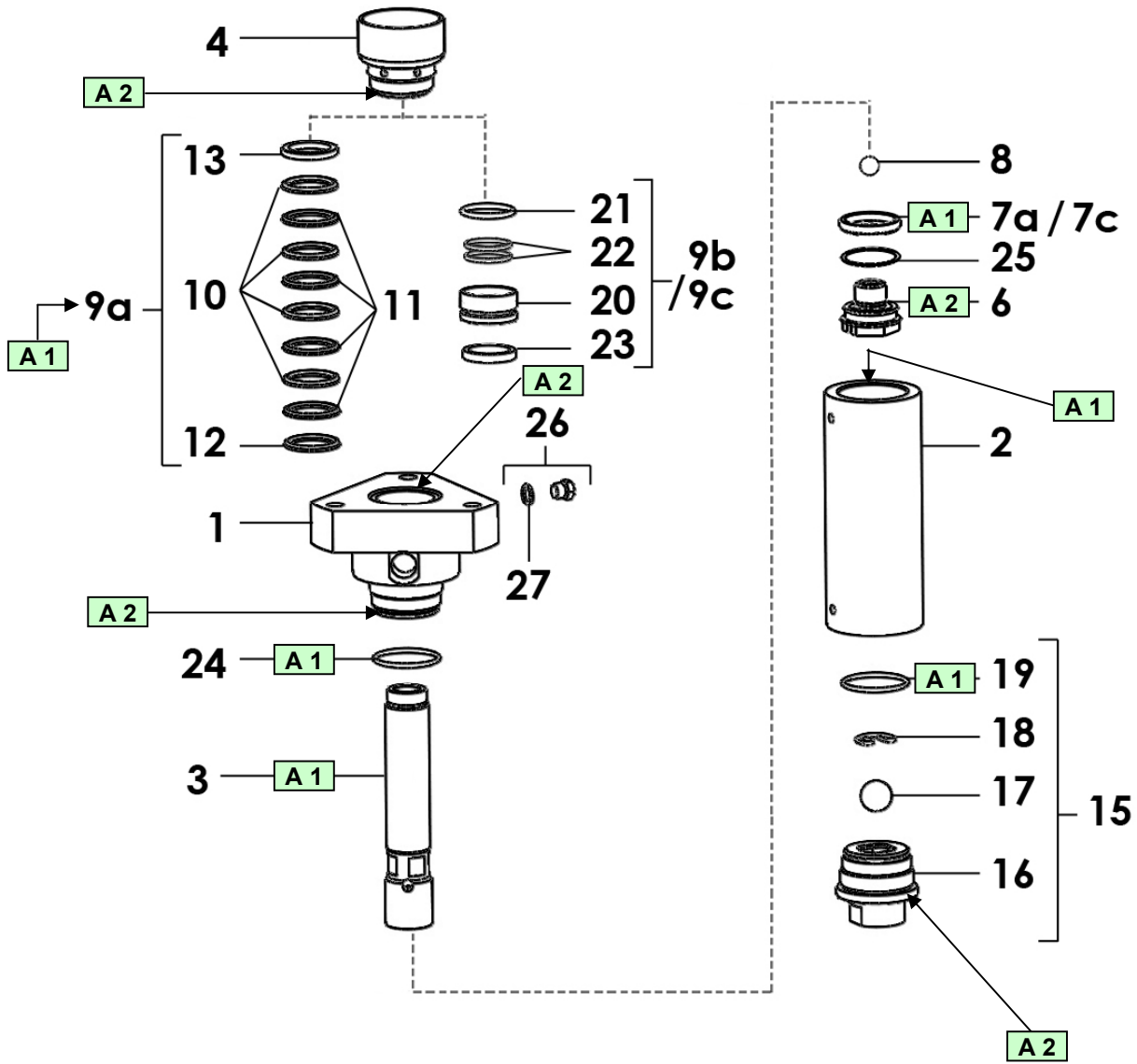

Index	Instruction	Description	Part number
<b>A 1</b>	PTFE grease	'TECHNILUB' grease (10 ml / 0.0026 US gal)	560.440.101
<b>A 2</b>	Anti-seize grease	Grease box (450 g / 0.99 lb)	560.420.005

<b>Doc. 573.412.050</b> Date/Datum/Fecha : 23/11/18 Annule/Cancela/ Ersetzt/Anula : 16/08/16	<b>Modif. / Änderung :</b> Mise à jour / Update / Aktualisierung / Actualización KREMLIN REXSON → SAMES KREMLIN ; 40.130_2 → 40C260, Ind. / Pos. 16	<b>Pièces de rechange</b> <b>Spare parts list</b> <b>Ersatzteilliste</b> <b>Piezas de repuesto</b>
---	--	---

<b>POMPE AIRLESS® INTENSIVE™,</b> <b>modèle 40C260</b>	<b>INTENSIVE™ AIRLESS PUMP,</b> <b>model 40C260</b>
<b>INTENSIVE™ AIRLESS PUMPE,</b> <b>Modell 40C260</b>	<b>BOMBA AIRLESS INTENSIVE™,</b> <b>tipo 40C260</b>

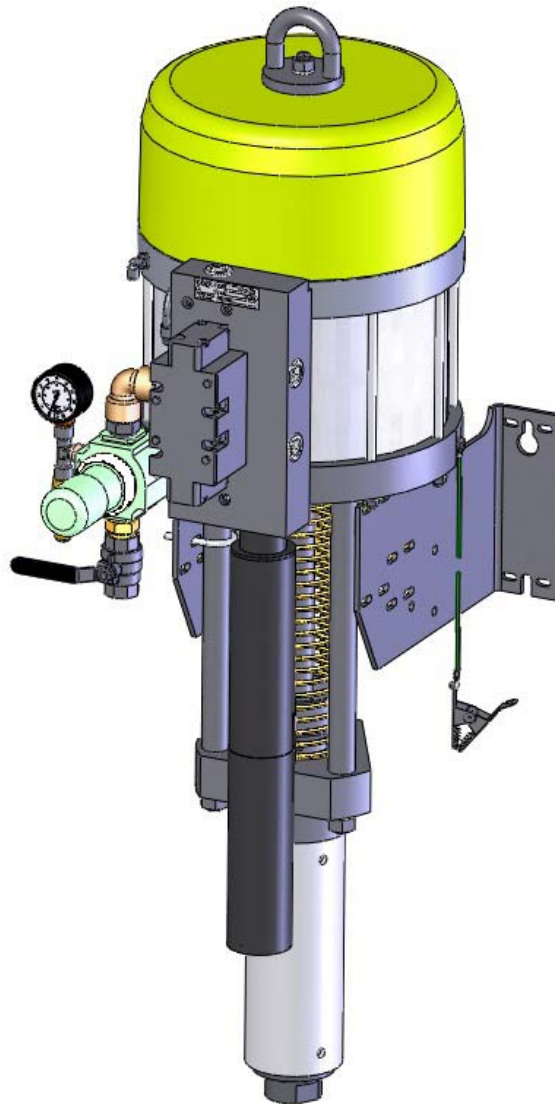

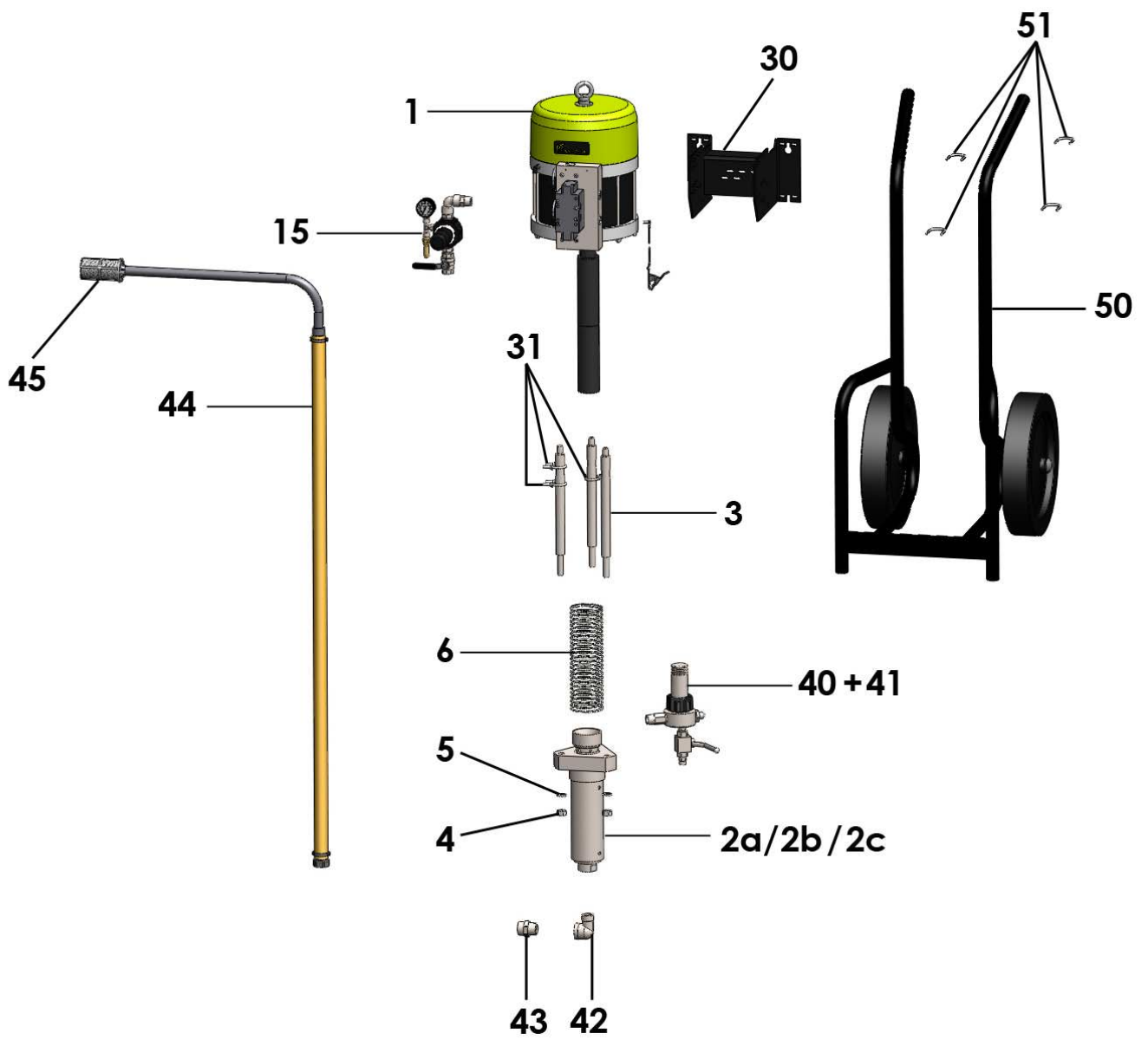

<b>POMPE MURALE, modèle 40C260</b>	<b>WALL MOUNTED PUMP, model 40C260</b>	<b>#</b>
<b>WANDANLAGE, Modell 40C260</b>	<b>BOMBA MURAL, tipo 40C260</b>	<b>151.870.500</b>

<b>POMPE MURALE, modèle 40C260 avec joints GT</b>	<b>WALL MOUNTED PUMP, model 40C260 with GT seals</b>	<b>#</b>
<b>WANDANLAGE, Modell 40C260 mit GT Dichtung</b>	<b>BOMBA MURAL, tipo 40C260 con juntas GT</b>	<b>NC / NS</b>

<b>POMPE MURALE, modèle 40C260 avec joints PU</b>	<b>WALL MOUNTED PUMP, model 40C260 with PU seals</b>	<b>#</b>
<b>WANDANLAGE, Modell 40C260 mit PU Dichtung</b>	<b>BOMBA MURAL, tipo 40C260 con juntas PU</b>	<b>NC / NS</b>

***Pièces communes - Common parts - Gleiche Teile - Partes comunes***

<b>Ind</b>	<b>#</b>	<b>Désignation</b>	<b>Description</b>	<b>Bezeichnung</b>	<b>Denominación</b>	<b>Qté</b>
-	NC / NS	<b>Pompe 40C260 nue</b>	<b>Bare pump, model 40C260</b>	<b>Pumpe 40C260 nackt</b>	<b>Bomba sola, tipo 40C260</b>	<b>1</b>
*1	NC / NS	▪ Moteur 5000.4_2 (voir Doc. 573.411.050)	▪ Air motor, model 5000.4_2 (refer to Doc. 573.411.050)	▪ Luftmotor, 5000.4_2 (siehe Dok. 573.411.050)	▪ Motor, tipo 5000.4_2 (consultar Doc. 573.411.050)	1
3	051 870 001	▪ Tirant	▪ Tie-rod	▪ Stehbolzen	▪ Tirante	3
4	953 010 025	▪ Ecrou HM 16	▪ Nut, model HM 16	▪ Mutter HM 16	▪ Tuerca, tipo HM 16	3
5	963 200 025	▪ Rondelle Ø 16	▪ Washer, model Ø 16	▪ Scheibe Ø 16	▪ Arandela, tipo Ø 16	3
6	050 311 904	▪ Ressort de protection	▪ Spring, protection	▪ Schutzfeder	▪ Muelle de protección	1
<b>15</b>	-	<b>Equipement d'air (voir page 4)</b>	<b>Air supply equipment (refer to page 4)</b>	<b>Luftausrüstung (siehe Seite 4)</b>	<b>Equipo de aire (consultar página 4)</b>	<b>1</b>
30	051 341 206	Support de pompe	Pump bracket	Wandhalterung	Soporte de bomba	1
31	NC / NS	Etrier avec rondelles et écrous	U-bolt with washers and nuts	Schelle mit Scheiben und Muttern	Tirante con arandelas y tuercas	3

**Pièces spécifiques - Specific parts - Spezifische Teile - Partes específicas**

**Mod. 40C260**

<b>Ind</b>	<b>#</b>	<b>Désignation</b>	<b>Description</b>	<b>Bezeichnung</b>	<b>Denominación</b>	<b>Qté</b>
*2a	144 025 600	▪ Hydraulique C260 inox (voir Doc. 573.414.050)	▪ Fluid section, model C260 (stainless steel) (refer to Doc. 573.414.050)	▪ Hydraulikteil, C260 Edelstahl (siehe Dok. 573.414.050)	▪ Hidráulica, tipo C260 de inox (consultar Doc. 573.414.050)	1

**Mod. 40C260 avec joints GT / with GT seals / mit GT Dichtung / con juntas GT**

<b>Ind</b>	<b>#</b>	<b>Désignation</b>	<b>Description</b>	<b>Bezeichnung</b>	<b>Denominación</b>	<b>Qté</b>
*2b	NC / NS	▪ Hydraulique C260 inox avec cartouche GT (voir Doc. 573.414.050)	▪ Fluid section, model C260 (stainless steel) with GT cartridge (refer to Doc. 573.414.050)	▪ Hydraulikteil, C260 Edelstahl mit GT Packung (siehe Dok. 573.414.050)	▪ Hidráulica, tipo C260 de inox con cartucho GT (consultar Doc. 573.414.050)	1

**Mod. 40C260 avec joints PU / with PU seals / mit PU Dichtung / con juntas PU**

<b>Ind</b>	<b>#</b>	<b>Désignation</b>	<b>Description</b>	<b>Bezeichnung</b>	<b>Denominación</b>	<b>Qté</b>
*2c	NC / NS	▪ Hydraulique C260 inox avec cartouche PU (voir Doc. 573.414.050)	▪ Fluid section, model C260 (stainless steel) with PU cartridge (refer to Doc. 573.414.050)	▪ Hydraulikteil, C260 Edelstahl mit PU Packung (siehe Dok. 573.414.050)	▪ Hidráulica, tipo C260 de inox con cartucho PU (consultar Doc. 573.414.050)	1

<b>POMPE MURALE, modèle 40C260 avec canne d'aspiration et filtre</b>	<b>WALL MOUNTED PUMP, model 40C260 with suction rod and filter</b>	<b>#</b>
<b>WANDANLAGE, Modell 40C260 mit Saugschlauch und Filter</b>	<b>BOMBA MURAL, tipo 40C260 con caña de aspiración y filtro</b>	<b>151.870.600</b>

Ind	#	Désignation	Description	Bezeichnung	Denominación	Qté
-	151 870 500	Pompe murale sans canne d'aspiration	Wall mounted pump without suction rod	Wandanlage ohne Saugschlauch	Bomba mural sin caña de aspiración	1
40	155 581 400	Filtre 3/4 équipé (voir Doc. 573.327.050)	Filter, model 3/4 equipped (refer to Doc. 573.327.050)	Ausgerüsteter Filter, Modell 3/4 (siehe Dok. 573.327.050)	Filtro, tipo 3/4 equipado (consultar Doc. 573.327.050)	1
*41	000 161 112	▪ Tamis n° 12 (280 µ)	▪ Screen n° 12 (280 µ)	▪ Sieb Nr 12 (280 µ)	▪ Tamiz n° 12 (280 µ)	1
42	905 210 404	Coude MF 1" inox	Elbow, model MF 1", stainless steel	Winkelnippel, Edelstahl AG 1" - IG 1"	Codo, tipo MH 1" de inox	1
43	050 102 449	Raccord inox MM 1" - 38 x 150	Fitting, model double male, 1" - 38 x 150 (stainless steel)	Doppelnippel, Edelstahl AG 1" - M 38 x 1,50	Racor de inox, tipo MM 1" - 38 x 150	1
44	049 597 100	Canne d'aspiration inox (Ø 25) avec crépine	Suction rod (stainless steel) with strainer	Saugschlauche mit Siebkorbe	Caña de aspiración (inox) con piña	1
*45	149 591 400	▪ Crépine avec manchon	▪ Strainer with sleeve	▪ Siebkorb	▪ Piña con manguito	1

<b>POMPE MURALE, modèle 40C260 sans canne d'aspiration avec filtre</b>	<b>WALL MOUNTED PUMP, model 40C260 without suction rod with filter</b>	<b>#</b>
<b>WANDANLAGE, Modell 40C260 ohne Saugschlauch mit Filter</b>	<b>BOMBA MURAL, tipo 40C260 sin caña de aspiración con filtro</b>	<b>151.870.800</b>

Ind	#	Désignation	Description	Bezeichnung	Denominación	Qté
-	151 870 500	Pompe murale sans canne d'aspiration	Wall mounted pump without suction rod	Wandanlage ohne Saugschlauch	Bomba mural sin caña de aspiración	1
40	155 581 400	Filtre 3/4 équipé (voir Doc. 573.327.050)	Filter, model 3/4 equipped (refer to Doc. 573.327.050)	Ausgerüsteter Filter, Modell 3/4 (siehe Dok. 573.327.050)	Filtro, tipo 3/4 equipado (consultar Doc. 573.327.050)	1
*41	000 161 112	▪ Tamis n° 12 (280 µ)	▪ Screen n° 12 (280 µ)	▪ Sieb Nr 12 (280 µ)	▪ Tamiz n° 12 (280 µ)	1
43	050 102 449	Raccord inox MM 1" - 38 x 150	Fitting, model double male, 1" - 38 x 150 (stainless steel)	Doppelnippel, Edelstahl AG 1" - M 38 x 1,50	Racor de inox, tipo MM 1" - 38 x 150	1

<b>POMPE MURALE, modèle 40C260 avec joints PU sans canne d'aspiration avec filtre</b>	<b>WALL MOUNTED PUMP, model 40C260 with PU seals without suction rod with filter</b>	<b>#</b>
<b>WANDANLAGE, Modell 40C260 Mit PU Dichtung ohne Saugschlauch mit Filter</b>	<b>BOMBA MURAL, tipo 40C260 con juntas PU sin caña de aspiración con filtro</b>	<b>151.870.660</b>

Ind	#	Désignation	Description	Bezeichnung	Denominación	Qté
-	NC / NS	Pompe murale avec joints PU sans canne d'aspiration	Wall mounted pump with GPU seals without suction rod	Wandanlage mit PU Dichtung ohne Saugschlauch	Bomba mural con juntas PU sin caña de aspiración	1
40	155 581 400	Filtre 3/4 équipé (voir Doc. 573.327.050)	Filter, model 3/4 equipped (refer to Doc. 573.327.050)	Ausgerüsteter Filter, Modell 3/4 (siehe Dok. 573.327.050)	Filtro, tipo 3/4 equipado (consultar Doc. 573.327.050)	1
*41	000 161 112	▪ Tamis n° 12 (280 µ)	▪ Screen n° 12 (280 µ)	▪ Sieb Nr 12 (280 µ)	▪ Tamiz n° 12 (280 µ)	1

<b>POMPE MURALE, modèle 40C260 avec joints GT sans canne d'aspiration avec filtre</b>	<b>WALL MOUNTED PUMP, model 40C260 with GT seals without suction rod with filter</b>	<b>#</b>
<b>WANDANLAGE, Modell 40C260 Mit GT Dichtung ohne Saugschlauch mit Filter</b>	<b>BOMBA MURAL, tipo 40C260 con juntas GT sin caña de aspiración con filtro</b>	<b>151.870.670</b>

Ind	#	Désignation	Description	Bezeichnung	Denominación	Qté
-	NC / NS	Pompe murale avec joints GT sans canne d'aspiration	Wall mounted pump with GT seals without suction rod	Wandanlage mit GT Dichtung ohne Saugschlauch	Bomba mural con juntas GT sin caña de aspiración	1
40	155 581 400	Filtre 3/4 équipé (voir Doc. 573.327.050)	Filter, model 3/4 equipped (refer to Doc. 573.327.050)	Ausgerüsteter Filter, Modell 3/4 (siehe Dok. 573.327.050)	Filtro, tipo 3/4 equipado (consultar Doc. 573.327.050)	1
*41	000 161 112	▪ Tamis n° 12 (280 µ)	▪ Screen n° 12 (280 µ)	▪ Sieb Nr 12 (280 µ)	▪ Tamiz n° 12 (280 µ)	1

<b>POMPE SUR CHARIOT, modèle 40C260</b>	<b>CART MOUNTED PUMP, model 40C260</b>	<b>#</b>
<b>PUMPE 40C260 FAHRBAR</b>	<b>BOMBA 40C260 SOBRE CARRETILLA</b>	<b>151.870.700</b>

Ind	#	Désignation	Description	Bezeichnung	Denominación	Qté
-	151 870 600	Pompe murale avec canne d'aspiration et filtre	Wall mounted pump with suction rod and filter	Wandanlage mit Saugschlauch und Filter	Bomba mural con caña de aspiración y filtro	1
50	051 231 000	Chariot	Cart	Fahrgestell	Carretilla	1
*51	151 730 114	Pochette 2 étriers, 4 rondelles, 4 écrous	Pack of 2 u-bolts, 4 washers, 4 nuts	Satz mit 2 Schellen, 4 Scheiben, 4 Muttern	Bolsa de 2 tirantes, 4 arandelas, 4 tuercas	2

EQUIPEMENT D'AIR (ind. 15)	AIR SUPPLY EQUIPMENT (ind. 15)
LUFTAUSRÜSTUNG (Pos. 15)	EQUIPO DE AIRE (índ. 15)

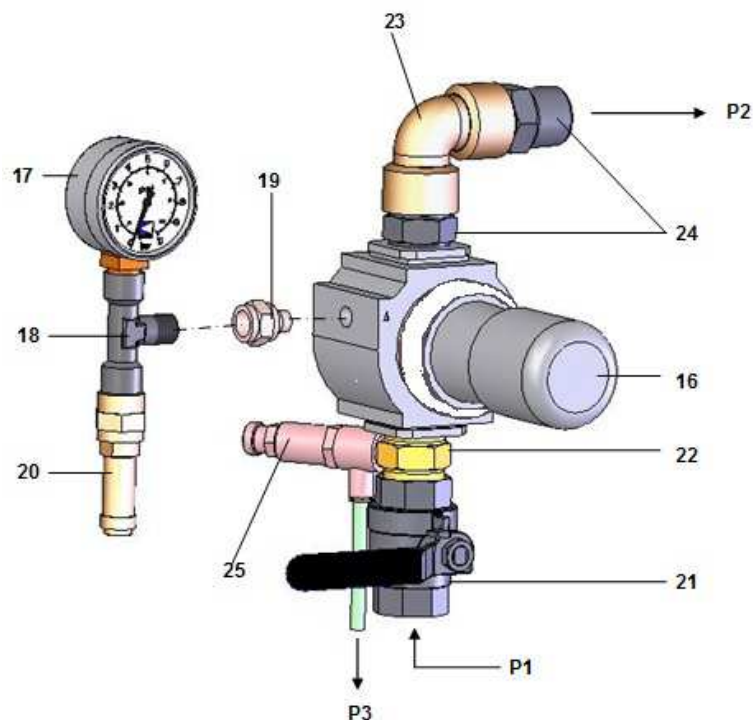

Ind	#	Désignation	Description	Bezeichnung	Denominación	Qté
*16	016 480 000	Détendeur d'air 3/4 0 - 10 bar (volant phosphore)	Air regulator, model 3/4 0 - 10 bar / 0 - 145 psi (pantone 382 knob)	Druckminderer, 3/4 0 - 10 bar (pantone 382 Stellglocke)	Manorreductor, tipo 3/4 0 - 10 bar (pomo de color 382)	1
*17	910 011 402	Manomètre 0 - 10 bar	Gauge, model 0 - 10 bar / 0 - 145 psi	Manometer, 0 - 10 bar	Manómetro, tipo 0 - 10 bar	1
18	552 441	Té 1/4"	Tee, model 1/4"	T-Stück, 1/4"	Té, tipo 1/4"	1
19	552 491	Raccord F 1/4" - M 1/8"	Fitting, model F 1/4" - M 1/8"	Nippel, IG 1/4" - AG 1/8"	Racor, tipo H 1/4" - M 1/8"	1
20	903 080 401	Soupape de décharge	Discharge-valve	Sicherheitsventil	Válvula de seguridad	1
21	903 090 208	Robinet F 3/4	Valve, F 3/4	Absperrhahn, IG 3/4	Grifo, tipo H 3/4	1
22	051 870 151	Raccord MM 3/4 BSP avec piquage	Fitting, model double male, 3/4 BSP	Doppelnippel AG 3/4 BSP	Racor, tipo MM 3/4 BSP	1
23	552 429	Coude FF 3/4"	Elbow, model FF 3/4"	Winkelnippel IG 3/4"	Codo, tipo HH 3/4"	1
24	050 102 215	Raccord MM 3/4 BSP	Fitting, model double male, 3/4 BSP	Doppelnippel AG 3/4 BSP	Racor, tipo MM 3/4 BSP	2
25	903 130 508	Régulateur de pression	Pressure air regulator	Druckreduzierventil	Regulador de presión	1

- \* Pièces de maintenance préconisées.
- \* Preceding the index number denotes a suggested spare part.
- \* Bezeichnete Teile sind empfohlene Ersatzteile.
- \* Piezas de mantenimiento preventivas.

- N C : Non commercialisé.
- N S : Denotes parts are not serviceable.
- N S : bezeichnete Teile gibt es nicht einzeln, sondern nur komplett .
- N S : no suministrado.

## Réglage / Adjustment / Einstellung / Ajuste

**P1 = 6 bar max. / 87 psi max.**

(arrivée air général / main air inlet / Hauptlufteingang / llegada aire general)

**P2 = 1 → 5,5 bar / 14.5 → 80 psi**

(air de puissance / power air / Arbeitsluft / aire de potencia)

**P3 = 4 bar max. / 58 psi max.**

(air de pilotage / pilot air / Steuerluft / aire de pilotaje)

Le régulateur (25) est préréglé en usine pour délivrer une pression de 4 bar max.

The regulator (25) is preset in the factory to give a maximum pressure of 4 bar / 58 psi.

Der Druckregler (25) ist werksseitig auf einen maximalen Steuerluftdruck von 4 bar eingestellt.

El regulador (25) se regula en la fábrica para suministrar una presión máxima de 4 bar.

### ACCESSOIRES - ACCESSORIES - ZUBEHÖR - ACCESORIOS

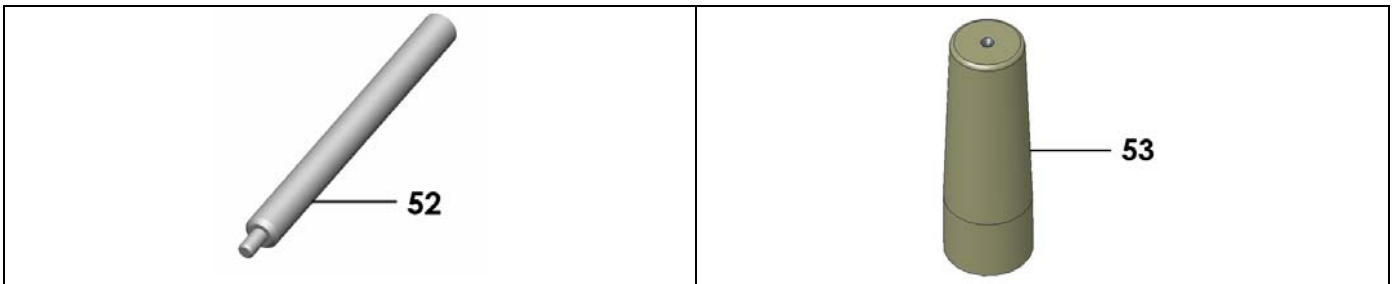

Ind	#	Désignation	Description	Bezeichnung	Denominación	Qté
-	149 990 020	Flacon de lubrifiant T (125 ml)	T lubricant (125 ml / 4.4 oz)	Spülmittel T (125 ml)	Botella de lubricante T (125 ml)	1
52	044 950 008	Clé (pour cuve presse-garniture)	Wrench (for wetting cup)	Schlüssel für Spülmitteltasse	Llave (para cubeta prensa guarnición)	1
53	051 881 459	Flamme : outillage pour montage garniture	Piston rod starter tool	Konus zur Montage der Kolbenstangenpackung	Herramienta para montar guarnición	1

<b>Doc. 573.411.050</b> Date/Datum/Fecha : 18/12/18 Annule/Cancela/ Ersetzt/Anula : 18/08/16	<b>Modif. / Änderung :</b> # 044 630 400 → NC (ind. 10a / Pos. 10a) + # 144 630 720 (ind. 10b / Pos. 10b)	<b>Pièces de rechange</b> <b>Spare parts list</b> <b>Ersatzteilliste</b> <b>Piezas de repuesto</b>
---	---	---

<b>MOTEUR A AIR, modèle 5000-4_2</b>	<b>AIR MOTOR, model 5000-4_2</b>	<b>#</b>
<b>LUFTMOTOR, Modell 5000-4_2</b>	<b>MOTOR DE AIRE, tipo 5000-4_2</b>	<b>146.280.200</b>

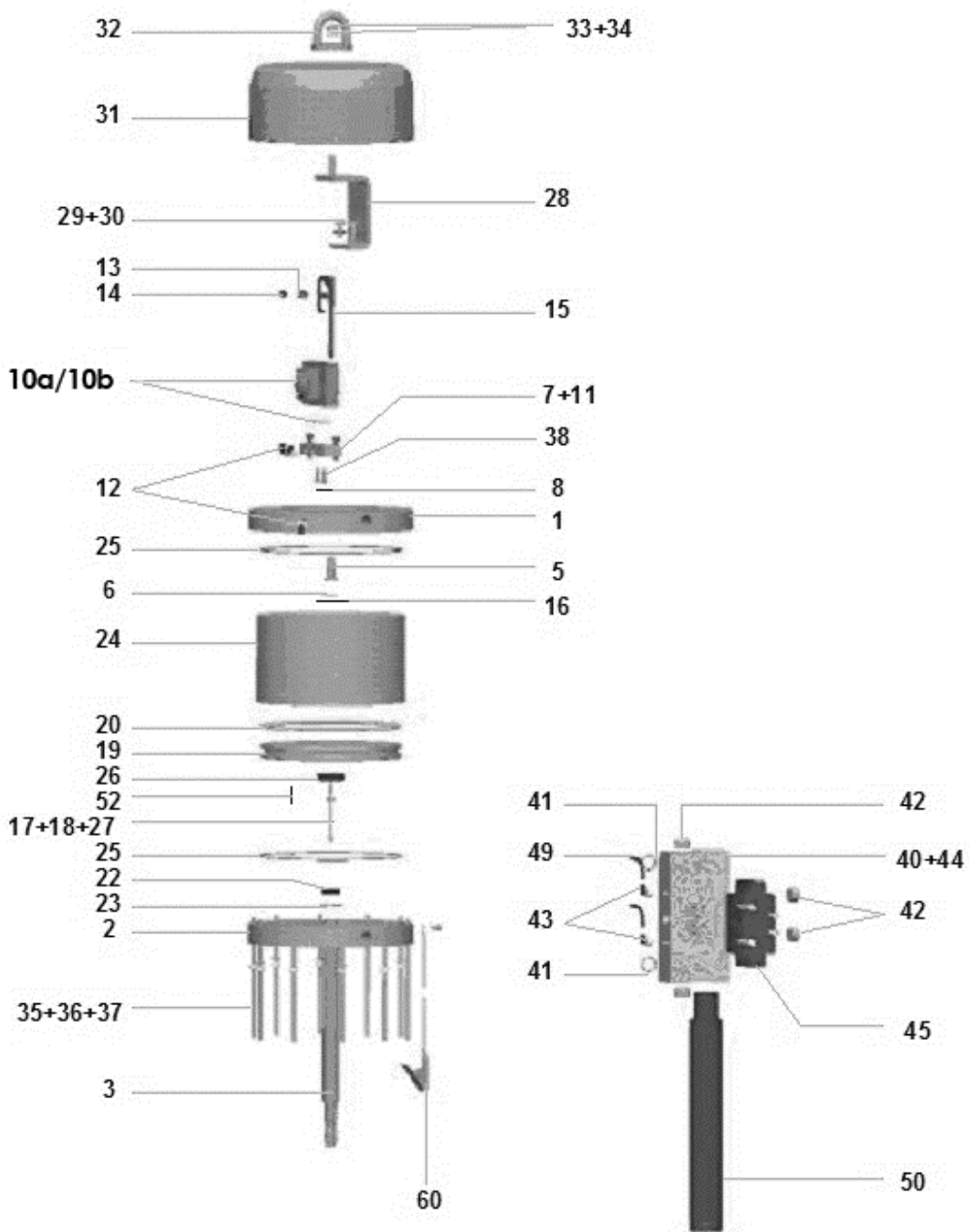

Ind	#	Désignation	Description	Bezeichnung	Denominación	Qté
1	NC / NS	Fond supérieur	Support, upper	Oberer Zylinderflansch	Fondo superior	1
2	NC / NS	Fond inférieur avec bague de guidage	Lower support with bushing guide	Unterer Zylinderflansch mit Führungsbuchse	Fondo inferior con anillo guía	1
3	046 280 202	Tige d'accouplement	Coupling rod	Kupplungsstange	Eje de acoplamiento	1
5	044 570 106	Bague de guidage	Bushing guide	Führungsbuchse	Anillo guía	1
6	144 579 923	Bague R 8 bis (x 10)	Ring, R 8 bis (x 10)	O Ring, R 8 bis (10 St.)	Anillo R 8 bis (x 10)	1
7	046 271 002	Embase du bloc inverseur	Base, reversing-block	Grundplatte, Umsteuerblock	Base bloque inversor	1
8	109 420 257	Bague O Ring (x 10)	O Ring (x 10)	O Ring (10 St.)	Anillo O Ring (x 10)	3
10a	NC / NS	Bloc inverseur (voir Doc. 573.087.040)	Reversing block (refer to Doc. 573.087.040)	Umsteuerblock (siehe Dok. 573.087.040)	Bloque inversor (consultar Doc. 573.087.040)	1
*10 b	144 630 720	Bloc inverseur droit avec deux roulements (voir Doc. 573.087.040)	Right reversing-block with two bearings (refer to Doc. 573.087.040)	Rechter Umsteuerblock mit zwei Lagerbuchsen (siehe Dok. 573.087.040)	Bloque inversor derecho con dos rodamientos (consultar Doc. 573.087.040)	1
11	930 151 446	Vis CHc M 8x35	Screw, model CHc M 8x35	Schraube M 8 x 35	Tornillo, tipo CHc M 8x35	2
12	905 120 905	Raccord coudé M 1/4 BSP - tuyau 4x6	Elbow, model M 1/4 BSP - hose 4x6	Winkel-Steckanschluss AG 1/4 BSP - Schlauch 4x6	Racor codo, tipo M 1/4 BSP - tubería 4x6	3
13	146 199 902	Ressort (x 10)	Spring (x 10)	Feder (10 St.)	Muelle (x 10)	1
14	044 570 131	Chape femelle	Linkage, female	Federhalterung	Unión hembra	1
15	044 570 900	Fourchette de commande	Fork assembly control	Umsteuerstange	Horquilla de mando equipada	1
16	902 202 002	Anneau de retenue Ø 24	Retaining ring, model Ø 24	Sicherungsring Ø 24	Anillo truarc, tipo Ø 24	1
17	046 180 003	Tige de pilotage	Rod, driving	Steuerstange	Eje de pilotaje	1
18	046 144 907	Ecrou	Nut	Mutter	Tuerca	1
*19	046 280 102	Piston moteur	Piston, air motor	Motorkolben	Pistón de motor	1
20	909 130 378	Joint de piston	Seal, piston	Kolbendichtung	Junta de pistón	1
22	046 280 106	Bague de frottement (x 2)	Seal ring (x 2)	Dichtring (2 St.)	Anillo de deslizamiento (x 2)	1
23	909 420 114	Joint	Seal	Dichtung	Junta	1
*24	046 280 007	Cylindre moteur	Cylinder, air motor	Luftzylinder	Cilindro de motor	1
25	909 420 293	Joint de cylindre	Seal, cylinder	Zylinderdichtung	Junta de cilindro	2
26	NC / NS	Ecrou inférieur	Lower nut	Untere Mutter	Tuerca inferior	1
27	044 570 107	Butée	Stop	Anschlag	Tope	1
28	NC / NS	Support de cloche	Cover support	Glockenhalterung	Soporte de campana	1
29	933 011 337	Vis CHc M 10x25	Screw, model CHc M 10x25	Schraube CHc M 10x25	Tornillo, tipo CHc M 10x25	2
30	963 040 021	Rondelle MN 10	Washer, model MN 10	Scheibe 10	Arandela, tipo MN 10	2
31	NC / NS	Cloche	Cover	Glocke	Campana	1
32	91 422	Anneau de levage	Ring, cover	Ringschraube	Anillo de transporte	1
33	953 010 023	Ecrou HM 12	Nut, model HM 12	Mutter HM 12	Tuerca, tipo HM 12	1
34	963 200 023	Rondelle	Washer	Scheibe	Arandela	1
35	044 710 007	Tirant moteur	Tie-rod, air motor	Stehbolzen	Tirante motor	10

Ind	#	Désignation	Description	Bezeichnung	Denominación	Qté
36	963 040 019	Rondelle MN 8	Washer, model MN 8	Scheibe MN 8	Arandela, tipo MN 8	10
37	953 010 019	Ecrou HM 8	Nut, model HM 8	Mutter HM 8	Tuerca, tipo HM 8	10
38	933 151 277	Vis CHc M 6x20	Screw, model CHc M 6x20	Schraube CHc M 6x20	Tornillo, tipo CHc M 6x20	2
40	NC / NS	Embase distributeur	Base, distributor	Grundplatte, Pneumatikventil	Base distribuidor	1
41	144 585 354	Joint d'embase (x 10)	Seal, base (x 10)	Dichtscheibe (x 10)	Junta de base (x 10)	2
42	906 333 105	Bouchon 3/4 BSP	Plug, model 3/4 BSP	Blindstopfen 3/4"	Tapón, tipo 3/4 BSP	4
43	905 120 905	Raccord coudé M 1/4 BSP - tuyau 4 x 6	Elbow, model M 1/4 BSP - hose 4 x 6	Winkelanschluss AG 1/4 BSP - Schlauch 4 x 6	Racor codo, tipo M 1/4 BSP - tubería 4 x 6	2
44	NC / NS	Vis CHc M 6 x 50	Screw, model CHc M 6 x 50	Schraube M 6 x 50	Tornillo, tipo CHc M 6 x 50	4
45	903 050 511	Distributeur ISO 5/2 - T3	Distributor, model ISO 5/2 - T3	5/2 Wege Pneumatikventil	Distribuidor, tipo ISO 5/2 - T3	1
49	NC / NS	Tuyau 4x6 (long. 0,5 m)	Hose 4x6 / 5/32" x 1/4" (0.5 m / 20" length)	Schlauch 4 x 6 (Länge: 0,5 m)	Tubería 4x6 (0,5 m de largo)	1
*50	046 250 015	Silencieux	Silencer	Schalldämpfer	Silenciador	1
52	932 173 145	Vis M 6 x 10	Screw, model M 6 x 10	Schraube, M 6 x 10	Tornillo, tipo M 6 x 10	1
60	901 180 024	Câble de mise à la terre (Lg. 5m) avec rondelle et vis	Cable ground (5 m / 197" length) with washer and screw	Erdungskabel (5 m) mit Scheibe und Schraube	Cable de puesta a tierra (5m de largo) con arandela y tornillo	1

Ind	#	Désignation	Description	Bezeichnung	Denominación	Qté
*	146 280 991	Pochette de joints moteur (ind. 6, 8(x3), 13, 20, 22, 23, 25(x2), 41(x2) + pochette de joints inverseur)	Seal kit (air motor) (ind. 6, 8(x3), 13, 20, 22, 23, 25(x2), 41(x2) + package of seals, reversing-block)	Dichtungssatz Motor (Pos. 6, 8(x3), 13, 20, 25(x2), 41(x2), + Dichtungssatz Umsteuerblock)	Bolsa de juntas motor (ind. 6, 8(x3), 13, 20, 22, 23, 25(x2), 41(x2) + bolsa de juntas inversor)	1
*	146 280 996	Pochette de maintenance (ind. 5 + pochette de joints moteur + ind. 2, 4, 7, 8, 13 de l'inverseur)	Servicing kit (ind. 5 + seal kit (air motor) + ind. 2, 4, 7, 8, 13 of the reversing-block)	Reparatursatz (Pos. 5 + Dichtungssatz für Luftmotor + Pos. 2, 4, 7, 8, 13 für Umsteuerblock)	Bolsa de reparación (ind. 5 + bolsa de juntas motor + ind. 2, 4, 7, 8, 13 del inversor)	1

\* Pièces de maintenance préconisées.

\* Preceding the index number denotes a suggested spare part.

\* Bezeichnete Teile sind empfohlene Ersatzteile.

\* Piezas de mantenimiento preventivas.

N C : Non commercialisé.

N S : Denotes parts are not serviceable.

N S : Bezeichnete Teile gibt es nicht einzeln, sondern nur komplett.

N S : no suministrado.

Nota : Les pompes dont le numéro de série est > à 17 K 1063 sont équipées du bloc inverseur # 144.630.720. Ne monter l'ind. 2 (bague de guidage du bloc inverseur) que si votre bloc comporte un R.

Nota : The pumps with serial number is > to 17 K 1063 are fitted with the reversing-block # 144.630.720. Install ind. 2 (guide ring of the reversing-block) only if your reversing-block has R.

Hinweis: Die Pumpen mit der Fertigungsnummer > bis 17 K 1063 sind mit dem Umsteuerblock # 144.630.720 bestückt. Die Pos. 2 (Führungsbuchse des Umsteuerblocks) nur am Umsteuerblock mit R Markierung montieren.

Nota : Las bombas cuyo número de serie es > a 17 K 1063 tienen el bloque inversor # 144.630.720. Montar el ind. 2 (anillo guía del bloque inversor) sólo si su bloque tiene un R.

<b>Doc. 573.087.040</b> Date/Datum/Fecha : 11/05/17 Annule/Cancela/ Ersetzt/Anula : 03/06/14	<b>Modif. / Änderung :</b> Mise à jour / Update / Aktualisierung / Actualización + 144.630.720	<b>Pièces de rechange</b> <b>Spare parts list</b> <b>Ersatzteilliste</b> <b>Piezas de repuesto</b>
---	---	---

<b>BLOC INVERSEUR</b>	<b>REVERSING-BLOCK</b>	<b>#</b>
<b>UMSTUEURBLOCK</b>	<b>BLOQUE INVERSOR</b>	<b>NC / NS</b>

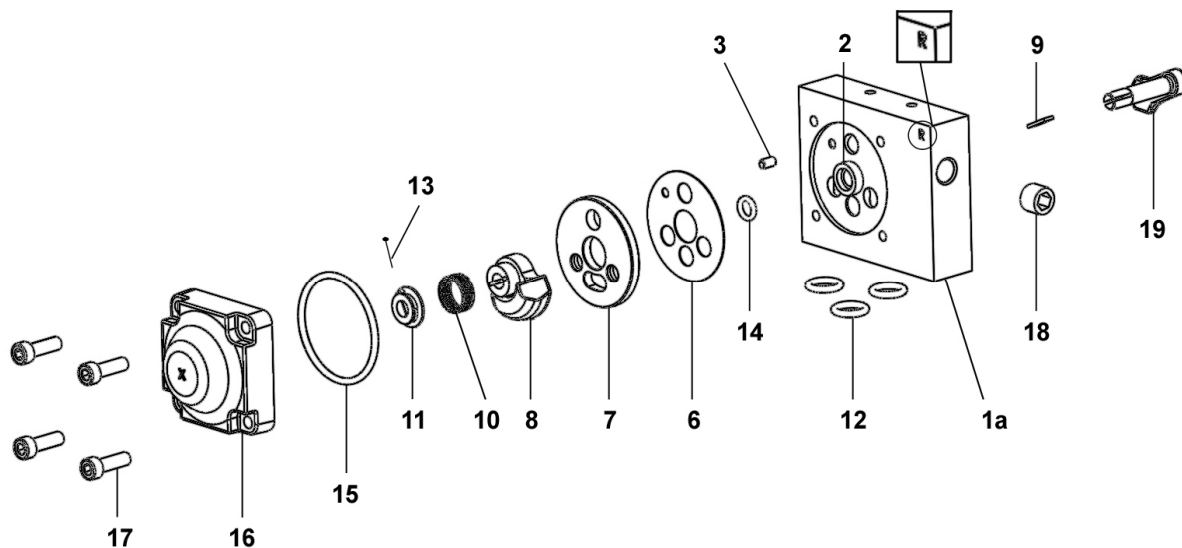

<b>BLOC INVERSEUR DROIT AVEC DEUX ROULEMENTS</b>	<b>RIGHT REVERSING-BLOCK WITH TWO BEARINGS</b>	<b>#</b>
<b>RECHTER UMSTUEURBLOCK MIT ZWEI LAGERBUCHSEN</b>	<b>BLOQUE INVERSOR DERECHO CON DOS RODAMIENTOS</b>	<b>144.630.720</b>

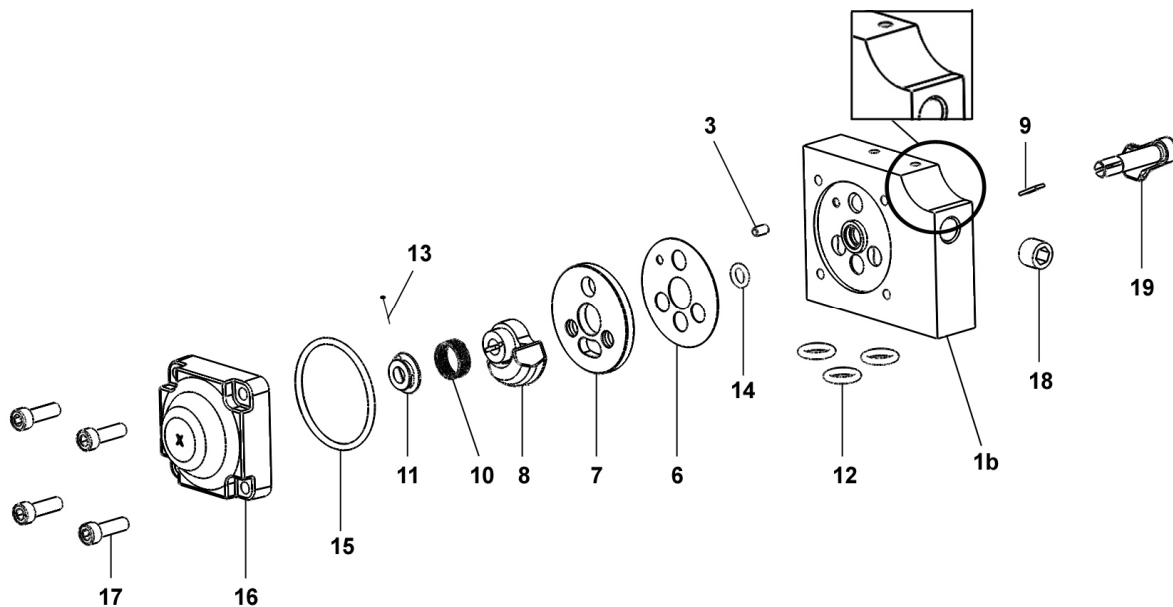

<b>BLOC INVERSEUR</b>	<b>REVERSING-BLOCK</b>	<b>#</b>
<b>UMSTUEERBLOCK</b>	<b>BLOQUE INVERSOR</b>	<b>NC / NS</b>

<b>BLOC INVERSEUR DROIT AVEC DEUX ROULEMENTS</b>	<b>RIGHT REVERSING-BLOCK WITH TWO BEARINGS</b>	<b>#</b>
<b>RECHTER UMSTUEERBLOCK MIT ZWEI LAGERBUCHSEN</b>	<b>BLOQUE INVERSOR DERECHO CON DOS RODAMIENTOS</b>	<b>144.630.720</b>

***Pièces communes - Common parts - Gleiche Teile - Partes comunes***

Ind	#	Désignation	Description	Bezeichnung	Denominación	Qté
*6	144 579 912	Joint de glace fixe (x 10)	Gasket seal (x 10)	Flachdichtung (10 x)	Junta de espejo fijo (x 10)	1
*7	046 170 508	Glace fixe	Base, fixed	Ventilplatte	Espejo fijo	1
*8	044 570 324	Glace mobile	Base, mobile	Ventilschieber	Espejo móvil	1
9	044 570 325	Clavette	Pin	Paßfeder (Keil)	Pasador	1
10	921 140 102	Ressort	Spring	Feder	Muelle	1
11	044 571 006	Butée de ressort	Stop, spring	Federführung	Tope de muelle	1
*12	144 579 922	Bague R 10 (x 10)	Ring, model R 10 (x 10)	O Ring R 10 (x 10)	Anillo, tipo R 10 (x 10)	3
*13	144 579 911	Goupille fendue (pochette de 10 goupilles + 1 butée ind. 11)	Pin (package of 10 pins + 1 stop ind. 11)	Splint (Satz à 10 Stück + 1 Führung Pos. 11)	Pasador (bolsa de 10 pasadores + 1 tope ind. 11)	1
*14	144 579 910	Bague R 6a (x 10)	Ring, model R 6a (x 10)	O Ring, R 6a (10 x)	Anillo, tipo R 6a (x 10)	1
*15	N C / N S	Joint de couvercle	Seal, cover	Deckeldichtung	Junta de tapa	1
16	144 630 415	Couvercle	Cover	Deckel	Tapa	1
17	933 151 277	Vis CHc M 6x20	Screw, model CHc M 6x20	Schraube, CHc M 6x20	Tornillo, tipo CHc M 6x20	4
18	906 333 102	Bouchon 1/4 BSP	Plug, model 1/4 BSP	Blindstopfen, 1/4 BSP	Tapón, tipo 1/4 BSP	1
19	046 170 510	Levier	Lever, control	Umsteuerhebel	Leva	1

Ind	#	Désignation	Description	Bezeichnung	Denominación	Qté
*	<b>146 270 950</b>	<b>Pochette de joints (ind. 6, 12(x3), 14, 15)</b>	<b>Package of seals (ind. 6, 12(x3), 14, 15)</b>	<b>Dichtungssatz (bestehend aus Pos. 6, 12(x3), 14, 15)</b>	<b>Bolsa de juntas (ind. 6, 12(x3), 14, 15)</b>	<b>1</b>
*	<b>144 630 425</b>	<b>Pochette de maintenance glaces (ind. 7, 8)</b>	<b>Servicing kit - bases (ind. 7, 8)</b>	<b>Servicekit - Ventil (Pos. 7, 8)</b>	<b>Bolsa de mantenimiento - espejos (ind. 7, 8)</b>	<b>1</b>

**Pièces spécifiques - Specific parts - Spezifische Teile - Partes específicas**

***Pour / for / für / para # NC / NS***

Ind	#	Désignation	Description	Bezeichnung	Denominación	Qté
*	<b>144 630 410</b>	<b>Corps équipé</b>	<b>Block assembly, reversing</b>	<b>Umsteuerblock komplett</b>	<b>Cuerpo equipado</b>	<b>1</b>
1a	N C / N S	▪ Corps	▪ Body	▪ Körper	▪ Cuerpo	1
2	N C / N S	▪ Bague de guidage	▪ Guide ring	▪ Führungsbuchse	▪ Anillo guía	1
3	N C / N S	▪ Goupille Ø 4 x 8	▪ Pin Ø 4 x 8	▪ Splint Ø4 x 8	▪ Pasador Ø 4 x 8	1
-	N C / N S	▪ Butée (collée sur corps ind.1a)	▪ Stop (glued on part ind. 1a)	▪ Anschlag (auf Körper geklebt ind.1a)	▪ Tope (pegado en cuerpo ind. 1a)	2
-	N C / N S	▪ Roulement à bille	▪ Ball bearing	▪ Kugellager	▪ Rodamiento de bolas	1

***Pour / for / für / para # 144.630.720***

Ind	#	Désignation	Description	Bezeichnung	Denominación	Qté
*	<b>144 630 715</b>	<b>Corps équipé</b>	<b>Block assembly, reversing</b>	<b>Umsteuerblock komplett</b>	<b>Cuerpo equipado</b>	<b>1</b>
1b	N C / N S	▪ Corps	▪ Body	▪ Körper	▪ Cuerpo	1
3	N C / N S	▪ Goupille Ø 4 x 8	▪ Pin Ø 4 x 8	▪ Splint Ø4 x 8	▪ Pasador Ø 4 x 8	1
-	N C / N S	▪ Butée (collée sur corps ind.1b)	▪ Stop (glued on part ind. 1b)	▪ Anschlag (auf Körper geklebt ind.1b)	▪ Tope (pegado en cuerpo ind. 1b)	2
-	N C / N S	▪ Roulement à bille	▪ Ball bearing	▪ Kugellager	▪ Rodamiento de bolas	2

\* Pièces de maintenance préconisées.

\* Preceding the index number denotes a suggested spare part.

\* Bezeichnete Teile sind empfohlene Ersatzteile.

\* Piezas de mantenimiento preventivas.

N C : Non commercialisé.

N S : Denotes parts are not serviceable.

N S : Bezeichnete Teile gibt es nicht einzeln, sondern nur komplett .

N S : no suministrado.

Nota : Ne monter l'ind. 2 (bague de guidage du bloc inverseur) que si votre bloc inverseur comporte un R.

Nota : Install ind. 2 (guide ring of the reversing-block) only if your reversing-block has R.

Hinweis: Die Pos. 2 (Führungsbuchse des Umsteuerblocks) nur am Umsteuerblock mit R Markierung montieren.

Nota : Montar el ind. 2 (anillo guía del bloque inversor) sólo si su bloque inversor tiene un R.

<p><b>Doc. 573.414.050</b>                  Date/Datum/Fecha : 09/02/21                  Annule/Cancela/                  Ersetzt/Anula : 26/11/18</p>	<p><b>Modif. / Änderung :</b>                  + # 144 025 691, # 144 025 692,                  # 144 025 693, # 144 025 694</p>	<p><b>Pièces de rechange</b>  <b>Spare parts list</b>  <b>Ersatzteilliste</b>  <b>Piezas de repuesto</b></p>
--	--	--

<b>HYDRAULIQUE INTENSIVE™,</b> modèle C260	<b>INTENSIVE™ FLUID SECTION,</b> model C260
<b>INTENSIVE™ HYDRAULIKTEIL,</b> model C260	<b>HIDRÁULICA INTENSIVE™,</b> model C260

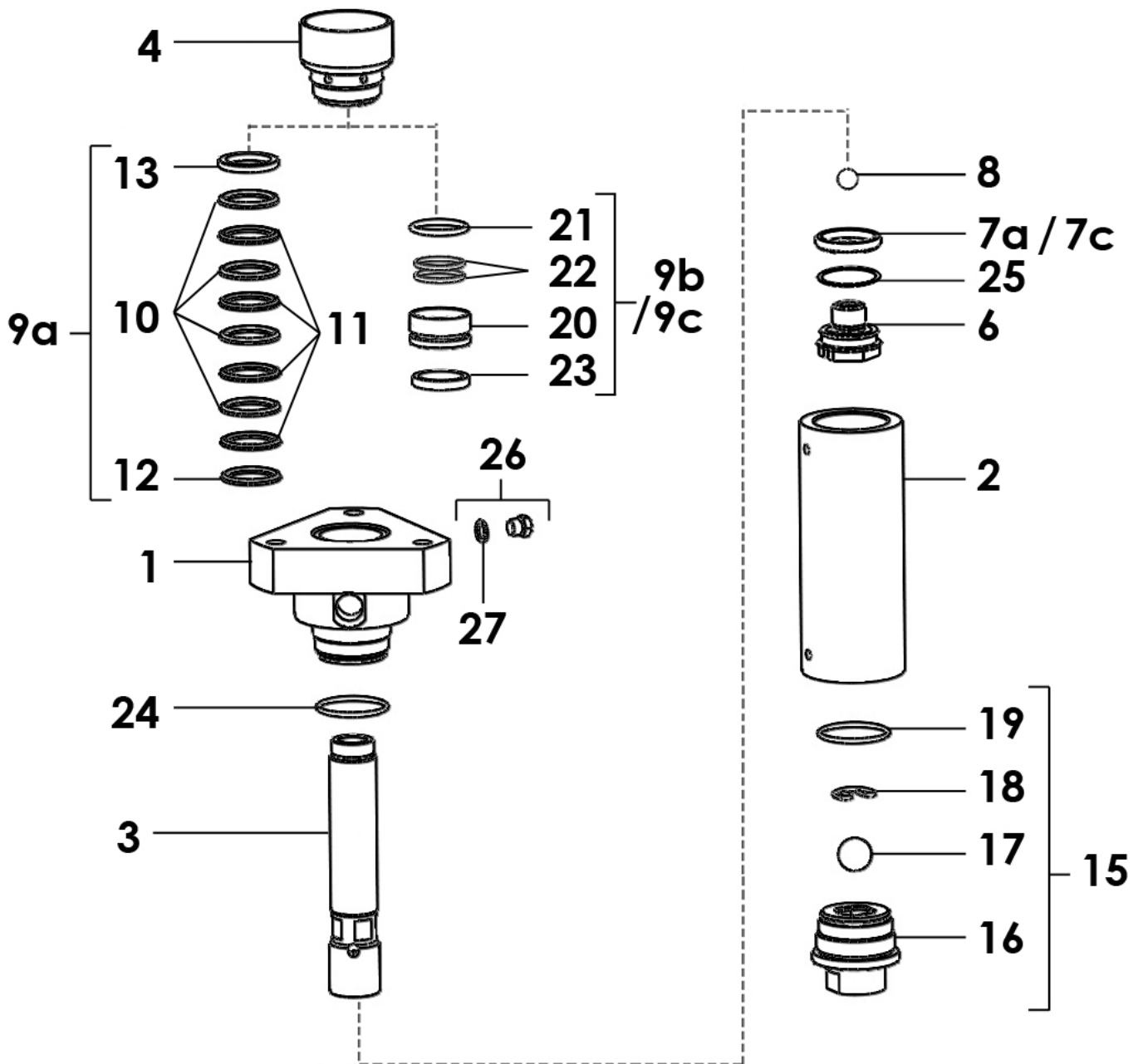

<b>HYDRAULIQUE INTENSIVE™, modèle C260</b>	<b>INTENSIVE™ FLUID SECTION, model C260</b>	<b>#</b>
<b>INTENSIVE™ HYDRAULIKTEIL, Modell C260</b>	<b>HIDRÁULICA INTENSIVE™, tipo C260</b>	<b>144.025.600</b>

<b>HYDRAULIQUE INTENSIVE™, modèle C260 AVEC CARTOUCHE GT</b>	<b>INTENSIVE™ FLUID SECTION, model C260 WITH GT CARTRIDGE</b>	<b>#</b>
<b>INTENSIVE™ HYDRAULIKTEIL, Modell C260 MIT GT PACKUNG</b>	<b>HIDRÁULICA INTENSIVE™, tipo C260 CON CARTUCHO GT</b>	<b>NC / NS</b>

<b>HYDRAULIQUE INTENSIVE™, modèle C260 AVEC CARTOUCHE PU</b>	<b>INTENSIVE™ FLUID SECTION, model C260 WITH PU CARTRIDGE</b>	<b>#</b>
<b>INTENSIVE™ HYDRAULIKTEIL, Modell C260 MIT PU PACKUNG</b>	<b>HIDRÁULICA INTENSIVE™, tipo C260 CON CARTUCHO PU</b>	<b>NC / NS</b>

***Pièces communes - Common parts - Gleiche Teile - Partes comunes***

<b>Ind</b>		<b>Désignation</b>	<b>Description</b>	<b>Bezeichnung</b>	<b>Denominación</b>	<b>Qté</b>
1	044 025 001	Bride supérieure	Upper flange	Oberer Flansch	Brida superior	1
*2	044 020 006	Cylindre	Cylinder	Materialzylinder	Cilindro	1
*3	044 020 602	Piston	Piston	Materialkolben	Pistón	1
4	044 970 004	Cuve presse-garniture	Wetting-cup	Packungsmutter /Spülmitteltasse	Cubeta prensa- guarnición	1
*6	144 020 620	Clapet de refoulement	Exhaust valve	Druckventil	Válvula de expulsión	1
8	907 414 242	Bille Ø 16, inox 440C	Ball Ø 16, stainless steel 440C	Kugel, Ø 16, Edelstahl, 440C	Bola Ø 16, inox 440C	1
<b>15</b>	<b>144 025 200</b>	<b>Clapet d'aspiration assemblé</b>	<b>Suction valve assembly</b>	<b>Saugventil, komplett</b>	<b>Válvula aspiración completa</b>	<b>1</b>
16	NC / NS	▪ Corps de clapet	▪ Valve body	▪ Saugventil	▪ Cuerpo de válvula	1
17	907 414 269	▪ Bille Ø 27,7, inox 440C	▪ Ball Ø 27,7, stainless steel 440C	▪ Kugel, Ø 27,7, Edelstahl 440C	▪ Bola Ø 27,7, inox 440C	1
18	044 695 010	▪ Jonc	▪ Rush	▪ Sicherungsring	▪ Anillo de retención bola	1
19	050 040 323	▪ Joint torique	▪ O Ring	▪ O-Ring	▪ Junta O Ring	1
24	050 040 323	Joint torique	O Ring	O-Ring	Junta O Ring	1
<b>26</b>	<b>144 950 012</b>	<b>Bouchon de vidange</b>	<b>Drain plug</b>	<b>Entleerungsschraube</b>	<b>Tapón de vaciado</b>	<b>1</b>
27	109 020 401	▪ Joint plat (x 5)	▪ Flat seal (x 5)	▪ Flachdichtung (5 Stück)	▪ Junta plana (bolsa de 5)	1

**Pièces spécifiques - Specific parts - Spezifische Teile - Partes específicas**

**Mod. C260 avec joints PTFE G PE / with PTFE G PE seals / mit PTFE G PE Dichtung  
/ con juntas PTFE G PE**

Ind	#	Désignation	Description	Bezeichnung	Denominación	Qté
7a	909 150 226	Joint GT	Seal, GT	GT-Dichtung	Junta GT	1
9a	-	Garniture supérieure	Upper packing	Obere Packung	Guarnición superior	1
10	909 050 820	▪ Joint chevron (PTFE G)	▪ Chevron seal (PTFE G)	▪ Packungsring, PTFE G	▪ Junta de chevrón (PTFE G)	4
11	909 051 102	▪ Joint chevron (PE)	▪ Chevron seal (PE)	▪ Packungsring, PE	▪ Junta de chevrón (PE)	4
12	044 025 004	▪ Rondelle d'appui male (inox)	▪ Male washer support (stainless steel)	▪ Unterer Stützring, außen (Edelstahl)	▪ Arandela de apoyo, macho (inox)	1
13	044 025 003	▪ Rondelle de serrage (inox)	▪ Blocking washer (stainless steel)	▪ Oberer Stützring, innen (Edelstahl)	▪ Arandela de apriete (inox)	1

**Mod. C260 avec joints GT / with GT seals / mit GT Dichtung / con juntas GT**

Ind	#	Désignation	Description	Bezeichnung	Denominación	Qté
7a	909 150 226	Joint GT	Seal, GT	GT-Dichtung	Junta GT	1
9b	144 710 100	Cartouche supérieure GT	Upper packing, GT	Obere Packung, GT	Cartucho superior (GT)	1
20	NC / NS	▪ Corps de cartouche GT	▪ Body, upper packing (GT)	▪ Körper (obere Packung)	▪ Cuerpo de cartucho GT	1
21	NC / NS	▪ Joint torique	▪ O Ring	▪ O-Ring	▪ Junta tórica	1
22	NC / NS	▪ Segment	▪ Ring	▪ Ring	▪ Segmento	2
23	NC / NS	▪ Joint GT	▪ GT seal	▪ GT Dichtung	▪ Junta GT	1

**Mod. C260 avec joints PU / with PU seals / mit PU Dichtung / con juntas PU**

Ind	#	Désignation	Description	Bezeichnung	Denominación	Qté
7c	909 060 303	Joint de piston (PU)	Piston seal (Polyurethane)	Kolbendichtung (PU)	Junta de pistón (Poliuretano)	1
9c	144 710 200	Cartouche supérieure PU	Upper packing, PU	Obere Packung, PU	Cartucho superior PU	1
20	NC / NS	▪ Corps de cartouche GT	▪ Body, upper packing (GT)	▪ Körper (obere Packung)	▪ Cuerpo de cartucho GT	1
21	NC / NS	▪ Joint torique	▪ O Ring	▪ O-Ring	▪ Junta tórica	1
22	NC / NS	▪ Segment	▪ Ring	▪ Ring	▪ Segmento	2
23	NC / NS	▪ Joint de tige	▪ Rod seal	▪ Kolben-Dichtring	▪ Junta de eje	1
25	044 990 047	▪ Rondelle de calage	▪ Adjustment block	▪ Höhenpassung	▪ Cuña de ajuste	1

**OPTIONS - ON REQUEST - OPTIONEN - OPCIONES**

Ind	#	Désignation	Description	Bezeichnung	Denominación	Qté
8	907 414 142	Bille Ø 16 inox 316	Ball Ø 16, 316 (stainless steel)	Kugel (Edelstahl), Ø 16, 316	Bola Ø 16, inox 316	1

**ACCESSOIRES - ACCESSORIES - ZUBEHÖR - ACCESORIOS**

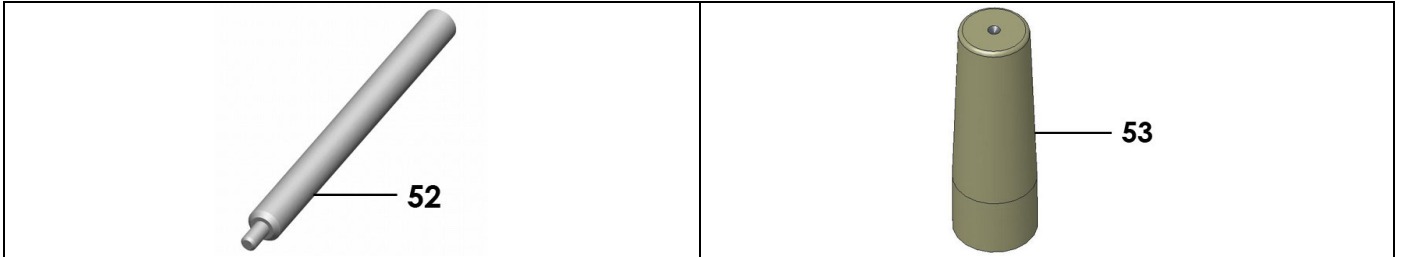

Ind	#	Désignation	Description	Bezeichnung	Denominación	Qté
-	149 990 020	Flacon de lubrifiant T (125 ml)	T lubricant (125 ml / 4.4 oz)	Spülmittel T (125 ml)	Botella de lubricante T (125 ml)	1
52	044 950 008	Clé (pour cuve presse- garniture)	Wrench (for wetting cup)	Schlüssel für Spülmitteltasse	Llave (para cubeta prensa guarnición)	1
53	051 881 459	Flamme : outillage pour montage garniture	Piston rod starter tool	Konus zur Montage der Kolbenstangenpackung	Herramienta para montar guarnición	1

Ind	#	Désignation	Description	Bezeichnung	Denominación	Qté
*	144 025 090	Pochette de joints - PTFE G / PE (ind. 7a, 8, 10 (x4), 11 (x4), 17, 18, 19 (x2), 24, 27)	Package of seals - PTFE G / PE (ind. 7a, 8, 10 (x4), 11 (x4), 17, 18, 19 (x2), 24, 27)	Dichtungssatz - PTFE G / PE (Pos. 7a, 8, 10 (x4), 11 (x4), 17, 18, 19 (x2), 24, 27)	Bolsa de juntas - PTFE G / PE (ind. 7a, 8, 10 (x4), 11 (x4), 17, 18, 19 (x2), 24, 27)	1
*	144 025 695	Pochette de maintenance joints - PTFE G / PE (ind. 6, 15 + pochette de joints # 144 025 090)	Servicing kit - PTFE G / PE (ind. 6, 15 + package of seals # 144 025 090)	Reparatursatz - PTFE G / PE (Pos. 6, 15 + Dichtungssatz # 144 025 090)	Bolsa de mantenimiento - PTFE G / PE (ind. 6, 15 + bolsa de juntas # 144 025 090)	1
*	144 025 691	Pochette de joints - PU (ind. 7c, 8, 9c, 17, 18, 19 (x 2), 24, 25, 27)	Package of seals - PU (ind. 7c, 8, 9c, 17, 18, 19 (x 2), 24, 25, 27)	Dichtungssatz - PU (Pos. 7c, 8, 9c, 17, 18, 19 (x 2), 24, 25, 27)	Bolsa de juntas - PU (ind. 7c, 8, 9c, 17, 18, 19 (x 2), 24, 25, 27)	1
*	144 025 692	Pochette de maintenance - PU (ind. 6, 15 + pochette de joints # 144 025 691)	Servicing kit - PU (ind. 6, 15 + package of seals # 144 025 691)	Reparatursatz - PU (Pos. 6, 15 + Dichtungssatz # 144 025 691)	Bolsa de mantenimiento - PU (ind. 6, 15 + bolsa de juntas # 144 025 691)	1
*	144 025 693	Pochette de joints - GT (ind. 7a, 8, 9b, 17, 18, 19 (x2), 24, 27)	Package of seals - GT (ind. 7a, 8, 9b, 17, 18, 19 (x2), 24, 27)	Dichtungssatz - GT (Pos. 7a, 8, 9b, 17, 18, 19 (x 2), 24, 27)	Bolsa de juntas - GT (ind. 7a, 8, 9b, 17, 18, 19 (x 2), 24, 27)	1
*	144 025 694	Pochette de maintenance - GT (ind. 6, 15 + pochette de joints # 144 025 693)	Servicing kit - GT (ind. 6, 15 + package of seals # 144 025 693)	Reparatursatz - GT (Pos. 6, 15 + Dichtungssatz # 144 025 693)	Bolsa de mantenimiento - GT (ind. 6, 15 + bolsa de juntas # 144 025 693)	1

\* Pièces de maintenance préconisées.

\* Preceding the index number denotes a suggested spare part.

\* Bezeichnete Teile sind empfohlene Ersatzteile.

\* Piezas de mantenimiento preventivas.

N C : Non commercialisé.

N S : Denotes parts are not serviceable.

N S : Bezeichnete Teile gibt es nicht einzeln, sondern nur komplett .

N S : no suministrado.

<b>Doc. 573.327.050</b> Date/Datum/Fecha : 15/11/18 Annule/Cancela/ Ersetzt/Anula : 10/10/11	<b>Modif. / Änderung :</b> Mise à jour / Update / Aktualisierung / Actualización	<b>Pièces de rechange</b> Spare parts list Ersatzteilliste Piezas de repuesto
---	--	--

<b>FILTRE PRODUIT HP, modèle 3/4 inox</b>	<b>HP FLUID FILTER, model 3/4 stainless steel</b>
<b>HP MATERIALFILTER, Modell 3/4 Edelstahl</b>	<b>FILTRO PRODUCTO AP, tipo 3/4 inox</b>

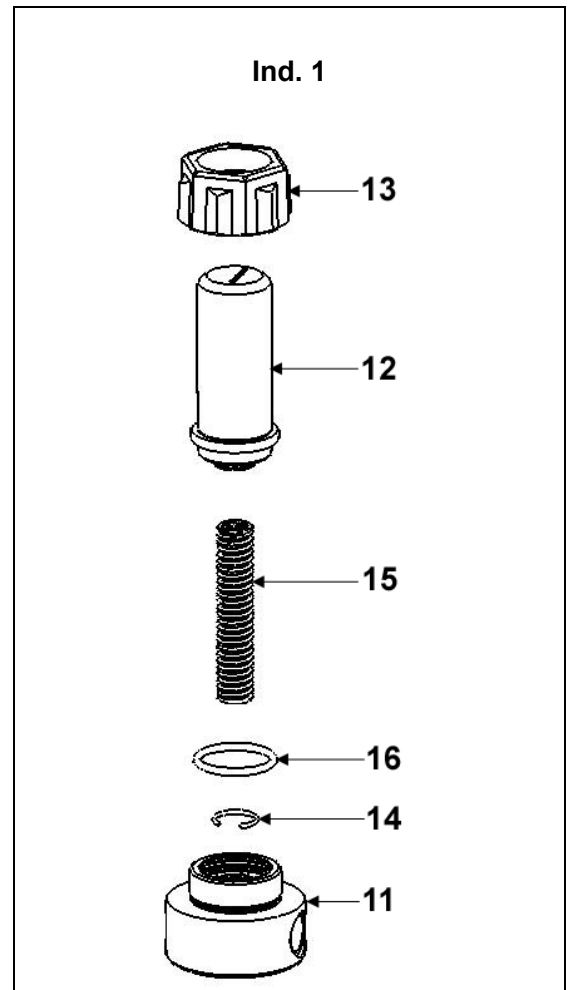
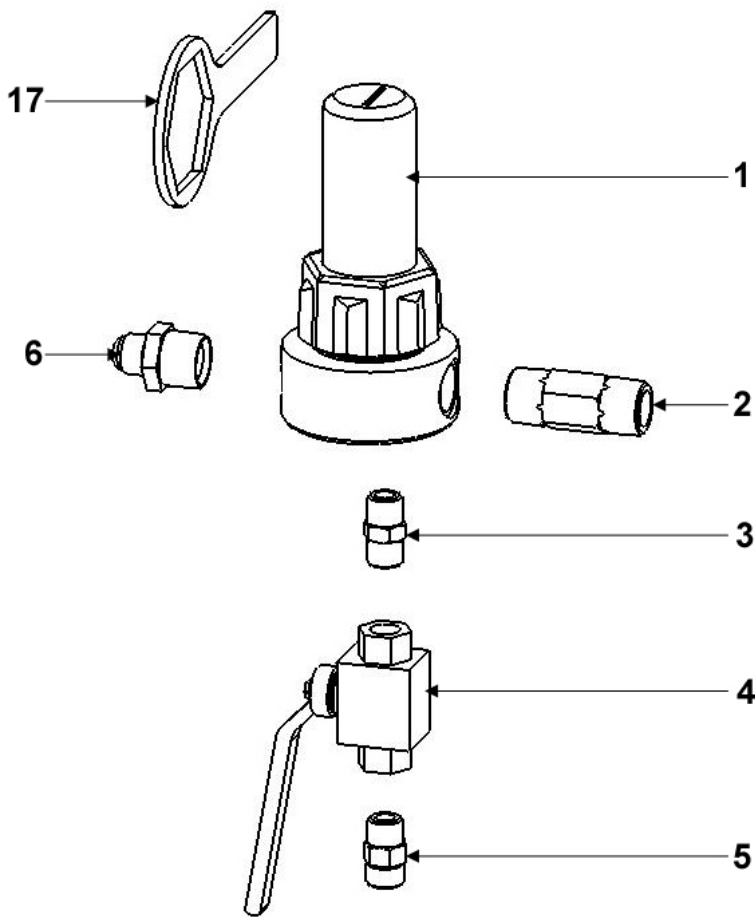

<b>FILTRE EQUIPÉ pour pompes AIRLESS®</b>	<b>EQUIPPED FILTER for AIRLESS pumps</b>	<b>#  155.581.400</b>
<b>AUSGERÜSTETER FILTER für AIRLESS-Pumpen</b>	<b>FILTRO EQUIPADO para bombas AIRLESS</b>	

Ind	#	Désignation	Description	Bezeichnung	Denominación	Qté
*1	155 581 450	Filtre nu inox (voir détail)	Bare filter, stainless steel (see detail)	Nackter Filter - Edelstahl (Siehe Detail)	Filtro solo, inox (consultar detalle)	1
2	055 581 401	Mamelon inox 3/4 NPS	Nippel 3/4 NPS, stainless steel	Rohnippel 3/4 NPS, Edelstahl	Pivote de centrado inox 3/4 NPS	1
3	905 240 002	Raccord inox MM 3/8 NPT	Fitting, double male, 3/8 NPT	Doppelnippel AG 3/8 NPT	Racor inox, MM 3/8 NPT	1
*4	903 090 220	Vanne HP FF 3/8 BSP	HP valve FF 3/8 BSP	Kugelhahn, IG 3/8 BSP	Válvula AP, HH 3/8 BSP	1
5	050 102 436	Raccord inox M 18 x 125 - M 3/8 BSP	Adaptor, stainless steel, double male 18x125 - 3/8BSP	Doppelnippel - Edelstahl AG 3/8 BSP - M 18x1,25	Racor inox, M 18 x 125 - M 3/8 BSP	1
6	905 210 515	Raccord inox M 3/4 NPT - M 3/4 JIC	Adaptor, stainless steel, double male, 3/4 NPT - # 8 JIC (3/4 JIC)	Doppelnippel Edelstahl 3/4 NPT - 3/4 JIC	Racor, inox M 3/4 NPT - M 3/4 JIC	1
*7	000 161 112	Tamis n° 12 (280 µ)	Screen n° 12 (280 µ - 55 Mesh)	Filterelement Sieb Nr. 12 (280 µ)	Tamiz n° 12 (280 µ)	1

<b>FILTRE NU (sans tamis)</b>	<b>BARE FILTER (without screen)</b>	<b>#  155.581.450</b>
<b>NACKTER FILTER (ohne Sieb)</b>	<b>FILTRO SOLO (sin tamiz)</b>	

Ind	#	Désignation	Description	Bezeichnung	Denominación	Qté
11	055 581 451	Embase 3/4	Base, model 3/4	Grundblock, Modell 3/4	Base, tipo 3/4	1
12	055 580 202	Cuve	Bowl	Filterglocke	Cubeta	1
13	055 280 002	Ecrou	Nut	Überwurfmutter	Tuerca	1
14	055 190 007	Jonc	Stop ring	Sicherungsring	Clips	1
15	055 190 005	Ressort	Spring	Feder	Muelle	1
*16	150 040 327	Joint (les 5)	Seal (pack of 5)	Dichtung (5 St.)	Junta (bolsa de 5)	1
17	049 030 018	Clé de démontage	Wrench	Schlüssel	Llave de desmontaje	1

\* Pièces de maintenance préconisées.

\* Preceding the index number denotes a suggested spare part.

\* Bezeichnete Teile sind empfohlene Ersatzteile.

\* Piezas de mantenimiento preventivas.

Ind. 7



Ind	#	Désignation	Description	Bezeichnung	Denominación	Qté
-	000 161 101	Tamis n° 1 (37 µ)	Screen n° 1 (37 µ)	Sieb Nr. 1 (37 µ)	Tamiz n° 1 (37µ)	1
-	000 161 102	Tamis n° 2 (77 µ)	Screen n° 2 (77 µ )	Sieb Nr. 2 (77 µ)	Tamiz n° 2 (77 µ)	1
-	000 161 104	Tamis n° 4 (99 µ)	Screen n° 4 (99 µ)	Sieb Nr. 4 (99 µ)	Tamiz n° 4 (99 µ)	1
-	000 161 106	Tamis n° 6 (168 µ)	Screen n° 6 (168 µ)	Sieb Nr. 6 (168 µ)	Tamiz n° 6 (168 µ)	1
-	000 161 108	Tamis n° 8 (210 µ)	Screen n° 8 (210 µ)	Sieb Nr. 8 (210 µ)	Tamiz n° 8 (210 µ)	1
<b>7</b>	<b>000 161 112</b>	<b>Tamis n° 12 (280 µ)</b>	<b>Screen n° 12 (280 µ)</b>	<b>Sieb Nr. 12 (280 µ)</b>	<b>Tamiz n° 12 (280 µ)</b>	<b>1</b>
-	000 161 115	Tamis n° 15 (360 µ)	Screen n° 15 (360 µ)	Sieb Nr. 15 (360 µ)	Tamiz n° 15 (360 µ)	1
-	000 161 020	Tamis n° 20 (510 µ)	Screen n° 20 (510 µ)	Sieb Nr. 20 (510 µ)	Tamiz n° 20 (510 µ)	1
-	000 161 030	Tamis n° 30 (750 µ)	Screen n° 30 (750 µ)	Sieb Nr. 30 (750 µ)	Tamiz n° 30 (750 µ)	1

OPTION - ON REQUEST - OPTIONEN - OPCIÓN

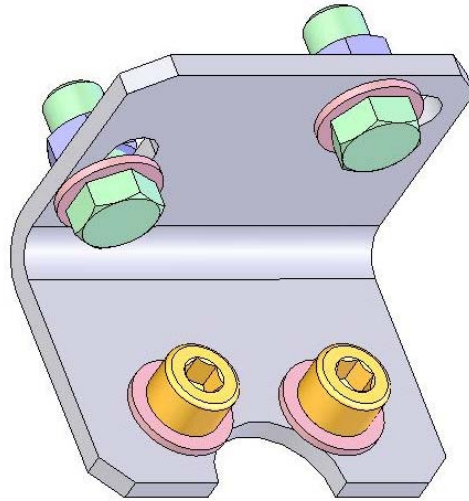

Ind	#	Désignation	Description	Bezeichnung	Denominación	Qté
-	155 190 105	Support filtre avec vis, rondelles et écrous	Mounting bracket with screws, washers and nuts	Filterhalterung mit Schrauben, Scheiben und Muttern	Soporte filtro con tornillos, arandelas y tuercas	1



# AIRLESS PUMP

## PREVENTIVE MAINTENANCE

### TRANSLATION FROM THE ORIGINAL MANUAL

***IMPORTANT : Before assembly and start-up, please read and clearly understand all the documents relating to this equipment (professional use only).***

THE PICTURES AND DRAWINGS ARE NON CONTRACTUAL. WE RESERVE THE RIGHT TO MAKE CHANGES WITHOUT PRIOR NOTICE.

**SAMES KREMLIN SAS**  
13, chemin de Malacher  
38 240 - MEYLAN - France  
☎ : 33 (0)4 76 41 60 60

**[www.sames-kremlin.com](http://www.sames-kremlin.com)**

## ■ PUMP

Make sure that the pump is clean and in good condition to increase equipment working life.

If the pump is a intensive™ one :

- Make sure the pump fluid outlet flange is always filled up with T lubricant (this T lubricant will normally be coloured by the paint).
- Regularly clean the wetting-cup with solvent after having drained the lubricant (Unscrew the plug placed at the upper flange).

**Guards (motor cover, coupling shields, connectors,...) have been designed for a safe use of the equipment.  
The manufacturer will not be held responsible for bodily injury or failure and / or property damage due to destruction, the overshadowing or the partial or total removal of the guards.**

Make sure that the suction strainer is clean and in good condition. Clean it regularly and replace it if it is necessary.

Flush the pump as often as necessary, specially when spraying pigment filled-material.

**Whatever the case, when stopping the pump, always leave it filled with material :  
For a short duration shutdown, if the flushing has not been carried out, leave the pump filled with material.  
For a long duration shutdown, after flushing, leave it filled with solvent.**

## ■ SPRAY GUN

Comply with the usual instructions of spray gun servicing (refer to spray gun manual).

## ■ FILTER

If the pump is equipped with a filter at the fluid outlet, comply with the usual instructions of filter servicing (refer to filter manual).



# HIGH PRESSURE PUMP FOR AIRMIX® AND AIRLESS SPRAYING TROUBLESHOOTING

## TRANSLATION FROM THE ORIGINAL MANUAL

***IMPORTANT : Before assembly and start-up, please read and clearly understand all the documents relating to this equipment (professional use only).***

THE PICTURES AND DRAWINGS ARE NON CONTRACTUAL. WE RESERVE THE RIGHT TO MAKE CHANGES WITHOUT PRIOR NOTICE.

**SAMES KREMLIN SAS**  
13, chemin de Malacher  
38 240 - MEYLAN - France  
☎ : 33 (0)4 76 41 60 60

**[www.sames-kremlin.com](http://www.sames-kremlin.com)**

CAUSE	SOLUTION
The pump does not start.	Check the pump air supply.
Priming trouble :  → Air is always coming out from the spray gun. → Air (or material) does not come out from the spray gun.	Be sure that the spray gun is fully opened and air evacuated through this one.  Air intake at the fitting or at the suction rod.  Check the pump valves. If a valve is stucked by dry paint, it can be unsticked without disassembling it. Blow air pressure directly by suction fitting.
The pump does not stop at once when shutting off the spray gun :  → The pump stops only on down stroke. → The pump stops only on up stroke.	Check exhaust valve or valve seal.  Check suction valve or upper cartridge.
The pump does not reverse.	Check spring of the air motor reversing-block. Lubricate reversing-block with HP 150 oil. Check if there is pilot air (depending on air motor model).
On intensive™ pump, the lubricant into the cup is fastly coloured.	Check the upper packing (tighten the cup or change seals if it is necessary).
On FLOWMAX® pump, leakage of fluid at the bottom of the air motor.	Check bellow.
Spraying trouble.	Refer to spray gun manual.
Decrease of material flow.	Refer to filter instruction manual.



**HIGH PRESSURE PUMP  
FOR AIRMIX® AND AIRLESS SPRAYING**

***OPERATING PRINCIPLE  
AND START-UP***

**TRANSLATION FROM THE ORIGINAL MANUAL**

***IMPORTANT : Before assembly and start-up, please read and clearly understand all the documents relating to this equipment (professional use only).***

THE PICTURES AND DRAWINGS ARE NON CONTRACTUAL. WE RESERVE THE RIGHT TO MAKE CHANGES WITHOUT PRIOR NOTICE.

**SAMES KREMLIN SAS**  
13, chemin de Malacher  
38 240 - MEYLAN - France  
☎ : 33 (0)4 76 41 60 60

**[www.sames-kremlin.com](http://www.sames-kremlin.com)**

## 1. OPERATING PRINCIPLE

The pump (A) consists of :

- an alternating air motor (B).
- an hydraulic section(C) mechanically coupled to the air motor (B).

The air motor is supplied with compressed air by means of the regulator knob (D) (pantone 382 colour knob). The pressure is read on the gauge (E).

During its alternating movement, the air motor drives the piston of the hydraulic section (C). The fluid is drawn in (L) and forced under pressure in (N). Due to its design, the pressure is always the one read on the gauge (E) x the pump ratio.

⇒ To adjust the fluid flow rate, turn the regulator knob (D) (pantone 382 colour knob) (Gauge E).

The pumps are intensive™ ones or FLOWMAX ® ones (with bellow).

## 2. START UP

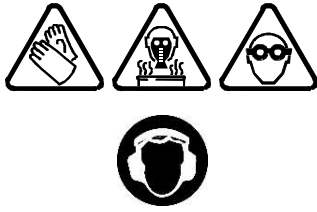

Protective clothing (gloves, protective masks, glasses, hearing protective earplug, protective clothing) should be worn to comply with the recommendations.

The working area must be correctly ventilated.

### 2-1 PUMP SUPPLIED IN SUCTION

STANDARD INTENSIVE™  
PUMP

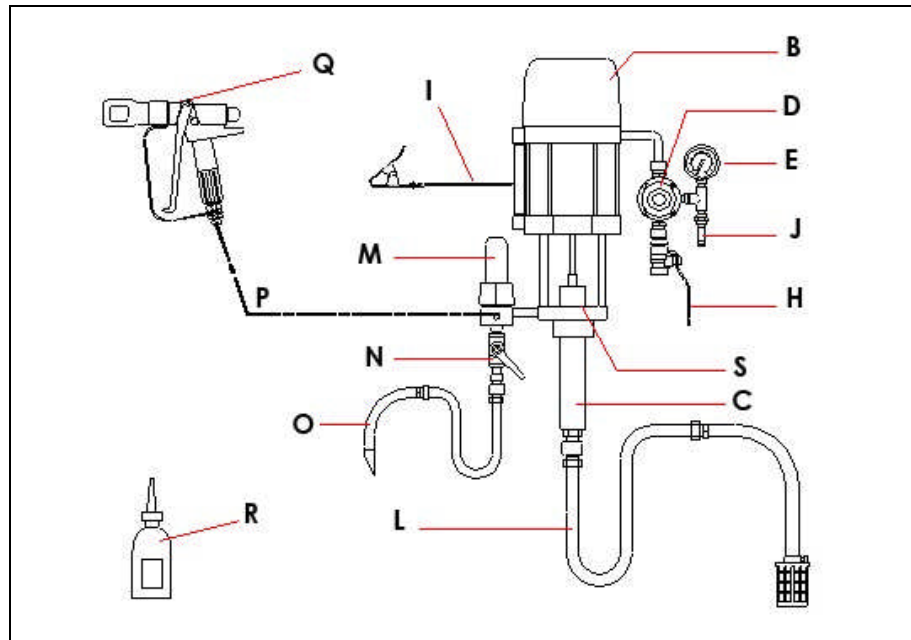

FLOWMAX® AIRLESS  
PUMP

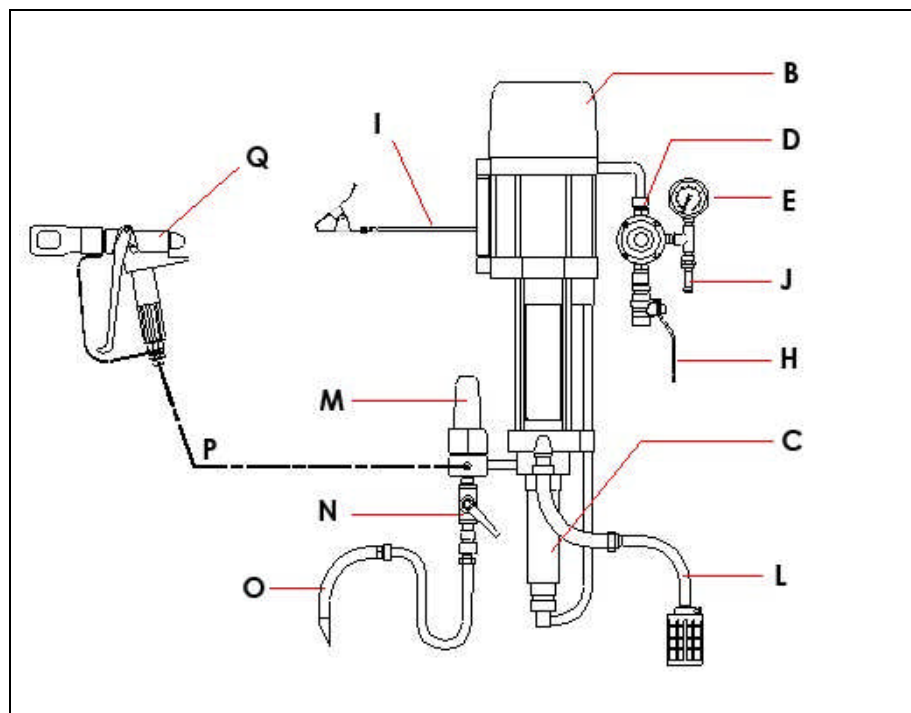

**Captions :**

A	Intensive™ or FLOWMAX® pump (B + C)	L	Suction rod (depending on version)
B	Air motor	M	Accumulator filter (depending on version)
C	Fluid section	N	Air shut off valve (depending on version)
D	'MOTOR AIR' air regulator	O	Air shut off rod (depending on version)
E	Gauge	P	HP Fluid hose
H	Air inlet valve	Q	Gun
I	Ground	R	T lubricant (125 ml / 4.4 oz) (only for intensive™ pump)
J	Relief valve	S	Wetting-cup (only for intensive™ pump)

(For specific installation, please contact your SAMES KREMLIN representative).

**Nota :** If the pump is equipped with an accumulator filter (M), the filter is supplied with a screen n° 12 (filtration size : 280 µ or 55 mesh). The screen is recommended for the use of an AIRLESS gun fitted with a nozzle model 20. If the fluid spraying is carried out by means of an other nozzle, please choose an other screen (refer to filter instruction manual). Adjust the screen to the application.

**Guards (air motor cover, coupling shields, housings ...) have been designed for safe use of the equipment.**

**The manufacturer will not be held responsible for bodily injury or failure and / or damage to property due to removal or partial removal of the guards**

**Start up procedure :**

- 1 - Ground the pump.
- 2 - **If the pump is a intensive™ one, fill up the wetting-cup (S) with "T" lubricant (R) or with an appropriate solvent.**
- 3 - Unscrew the air regulator (D).
- 4 - Interconnect the equipment with the air pressure network (clean air - P < 6 bar / 87 psi). Install a water drop, model 3/4" if it is necessary.
- 5 - Connect all the hoses , compressed air general supply hose and fluid hose (P), as well as the gun (Q).  
**Nota :** Comply with the diameters of hoses recommended in the specifications of the pump.
- 6 - Remove the nozzle from the gun.

■ **FLUSHING WITH SOLVENT**

- 7 - Immerse suction rod (L) and air shut off rod (O) into the material container.
- 8 - Open air shut off valve (N).
- 9 - Open the valve (H) of the pump air equipment to supply the air motor.  
**Nota :** If the air motor is a 5000 or a 8000 version, it needs pilot air to operate. The pump air equipment supplies pilot air to the air motor. The air supply pressure is adjusted previously in the factory to 4 bar / 58 psi maximum.
- 10 - Increase the air regulator (D) so that the pump runs slowly (Pressure between 0.5 and 1 bar / 7.25 to 14.503 psi).
- 11 - Observe the drain (O); air bubbles come out from it. When bubbles no longer come out from it, shut off the drain valve (N).

▪ **PRIMING WITH MATERIAL**

- 12 - Remove suction rod (L) and drain rod (O) from material container and immerse them in a solvent filled container.
- 13 - Open drain valve (N), wait until the material flows out regularly, then shut off the drain valve (N).
- 14 - Point the spray gun towards the material container and trigger the gun until the material flows out regularly.

▪ **WORK**

- 12 - Remove suction rod (L) and drain rod (O) from material container and immerse them in a solvent filled container.
- 13 - Open drain valve (N), wait until the material flows out regularly, then shut off the drain valve (N).
- 14 - Point the spray gun towards the material container and trigger the gun until the material flows out regularly.

**Nota** : Some of these pumps are designed for AIRMIX ® spraying when using long hoses and medium or high viscosity fluids.

For this use, a spraying air kit shall be mounted on the pump air supply in order to feed compressed air to the spray gun.

**2-2 PUMP SUPPLIED IN FILLING (CIRCULATING)**

Interconnect the fluid inlet of the pump with the circulating supply hose and start up the pump as it is specified previously.

**If the pump is a FLOWMAX ® one :**

**WARNING:**

- **Fluid section filling pressure** : 2 bar maximum / 29 psi maximum
- **WARNING : Do not create overpressure.**
- **Never use** the pump when **an isolating gate on the supply circuit** (upstream from the FLOWMAX ® fluid section) is shut : **it would damage the bellows.**
- **Do not install** a material regulator on the supply circuit or any arrangement that could perform as a non-return valve.

### 3. SHUTDOWN AT THE END OF THE WORK

#### ▪ SHORT DURATION SHUTDOWN

- 1 - Decrease the material pressure of air regulator (D) until reading **0 bar / 0 psi** on gauge (E).
- 2 - Trigger the gun to depressurize the system.
- 3 - Remove the nozzle of the spray gun and soak it into solvent.

#### ▪ LONG DURATION SHUTDOWN

- 1 - Decrease the material pressure of air regulator (D) until reading **1 bar / 14.503 psi** on gauge (E).
- 2 - Remove the nozzle from the spray gun and soak it into solvent.
- 3 - Open the drain valve. The pump must operate at low speed. If the speed is too high, decrease the pump air pressure (D).
- 4 - Remove the suction rod and the drain rod from the material container and immerse it in a solvent-filled container. Take all the appropriate precautions in the presence of flammable solvents.
- 5 - When the solvent flows out clear and clean, close the drain valve.
- 6 - Point the spray gun towards the material container and press the gun trigger. When the solvent flows out, point the gun towards the recovery container.
- 7 - When the solvent flows out regularly, release the spray gun trigger.

**Nota : If the pump is a intensive™ one, release the spray gun trigger when the pump piston is in a low position. To prevent from damaging the seals when starting once again the pump, the piston must be immersed into solvent.**

- 8 - Fully unscrew the air regulator (D) and shut off the main compressed air valve (valve H).
- 9 - Trigger the spray gun trigger to decompress the hoses. Therefore, the pump and the hose remain filled with solvent at the atmospheric pressure.

### 4. SAFETY DEVICE

**Guards (air motor cover, coupling shields, housings ...) have been designed for safe use of the equipment.**

**The manufacturer will not be held responsible for bodily injury or failure and / or damage to property due to removal or partial removal of the guards**

A relief-valve (setting : 6.5 bar / 94 psi) is fitted on the pump air motor - thus protecting this one from an overpressure which could damage it.

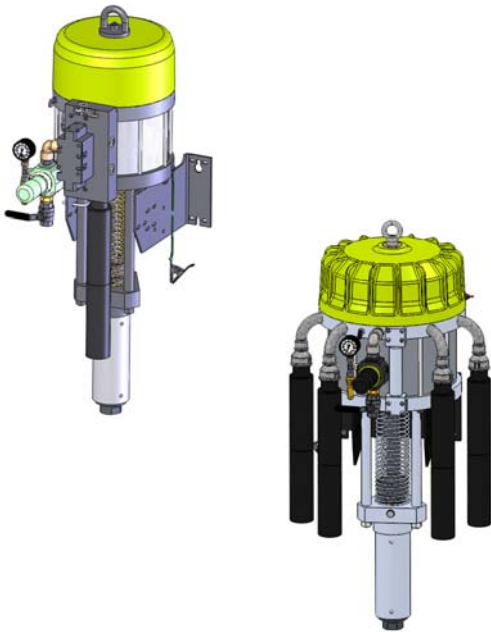

## AIRLESS PUMPS

**40C260**

**65C260**

**TECHNICAL FEATURES**

### TRANSLATION FROM THE ORIGINAL MANUAL

***IMPORTANT : Before assembly and start-up, please read and clearly understand all the documents relating to this equipment (professional use only).***

THE PICTURES AND DRAWINGS ARE NON CONTRACTUAL. WE RESERVE THE RIGHT TO MAKE CHANGES WITHOUT PRIOR NOTICE.

**SAMES KREMLIN SAS**  
13, chemin de Malacher  
38 240 - MEYLAN - France  
☎ : 33 (0)4 76 41 60 60

**[www.sames-kremlin.com](http://www.sames-kremlin.com)**

## 1. DESCRIPTION

- High output pneumatic pump, stainless steel
- Low maintenance and ease of use

### Designed for :

- Supplying one or several guns, model AIRLESS or AIRMIX® 200
- Spraying semi-fluids materials (anticorrosion material, glue)
- Circulating

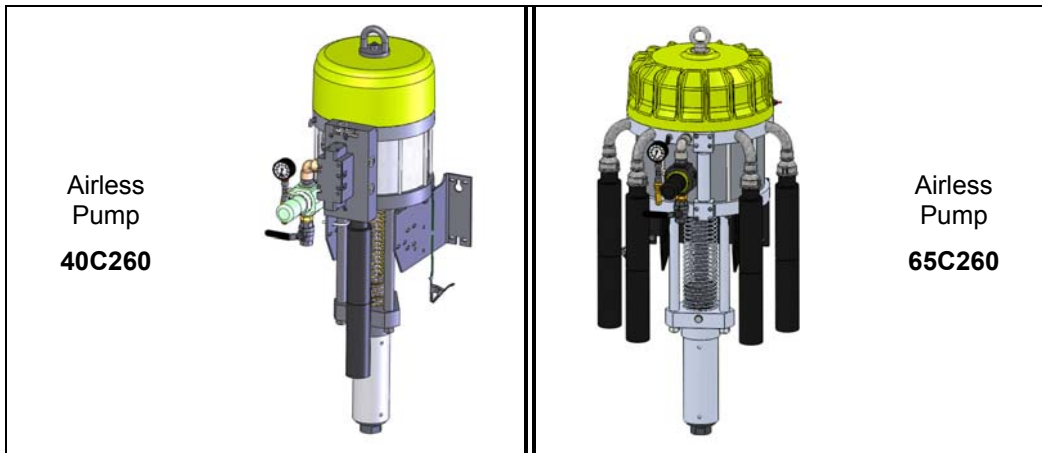

## 2. TECHNICAL FEATURES

### ■ FEATURES - PUMP, MODEL 40C260

Motor model .....5000-4\_2  
 Body pump model .....C260  
 Theoretical pressure ratio .....40/1

#### Wetted parts :

Hard chrome stainless steel  
 Stainless steel, Carbide

#### Tightness packings :

Upper fixed : PTFE G + PE or GT or PU  
 Lower, mobile : GT seal or PU

Air motor stroke	100 mm	4"
Air motor section	490 cm <sup>2</sup>	75.95 sq.in
Fluid section	12 cm <sup>2</sup>	1.9 sq.in
Delivery per cycle	240 cm <sup>3</sup>	8.5 oz
Number of cycle	4 per liter	15 US Gal
Flow (20 cycles)	4,8 l	1.27 US Gal
Air pressure operating pressure	6 bar	88 psi
Maximum discharge pressure	240 bar	3480 psi
Weighted sound pressure (LAeq)	85 dBa*	85 dBa*
Maximum operating temperature	60°C	140 °F

Weight : Wall mounted pump with suction rod ..... 110 kg / 242 lb  
 Cart mounted pump ..... 140 kg / 309 lb

#### \* Test conditions - Noise level :

- Test duration : 30 s,
- Motor air pressure : 6 bar,
- Material used : water,
- Flow rate : Pump adjusted at 20 cycles/minute

▪ **FEATURES - PUMP, MODEL 65C260**

Motor model .....8000-4_2	Air motor stroke	100 mm	4"
Body pump model .....C260	Air motor section	804 cm <sup>2</sup>	125 sq.in
Theoretical pressure ratio .....65/1	Fluid section	12 cm <sup>2</sup>	1.9 sq.in
<b>Wetted parts :</b>	Delivery per cycle	240 cm <sup>3</sup>	8.5 oz
Hard chrome stainless steel	Number of cycle	4	15 US gal
Stainless steel, carbide	Flow (20 cycles)	4.8 l	1.27 US gal
<b>Tightness packings :</b>	Maximum air operating pressure	6 bar	88 psi
Upper fixed : PTFE G + PE	Maximum discharge pressure	390 bar	5656 psi
Lower, mobile : GT seal	Weighted sound pressure (LAeq)	78 dBa*	78 dBa*
	Maximum operating temperature	60° C	140° F

**Weight :** Wall mounted pump with suction rod ..... 120 kg / 265 lb  
 Cart mounted pump ..... 150 kg / 330 lb

\* **Test conditions - Noise level :**

- Test duration : 30 s,
- Motor air pressure : 6 bar,
- Material used : water,
- Flow rate : Pump adjusted at 20 cycles/minute

▪ **FITTINGS**

		Bare pump	Pump assembly
Air	Inlet	F 3/4 BSP (valve)	F 3/4 BSP (valve)
Fluid	Inlet	F 1" BSP	Elbow MF 1" + fitting, double male 1" - 38x150 + Suction rod (fitting F 38x150)
	Outlet	F 3/4 NPS	# 8 JIC (Male 3/4 JIC) (filter outlet)

▪ **HOSES WITH FITTINGS**

Pump air supply hose (minimum Ø for a 5 m / 16.5 ft length) : Ø 20 mm / 3/4 dia.  
 AIRLESS fluid hose (between pump fluid outlet and gun) : Ø 9.52 mm int. / Ø 3/8 ID.

■ DIMENSIONS OF THE PUMP, MODEL 40C260

Ind.	mm	"	Ind.	mm	"	Ind.	mm	"
A	1460	57.5	B	1165	45.86	C	725	28.54
D	390	15.35	E	1120	44.1	F	510	20.07
G	Ø 300	Ø 11.8 -13/16	H	530	20.86	I	414	16.30
J	180	7.1						

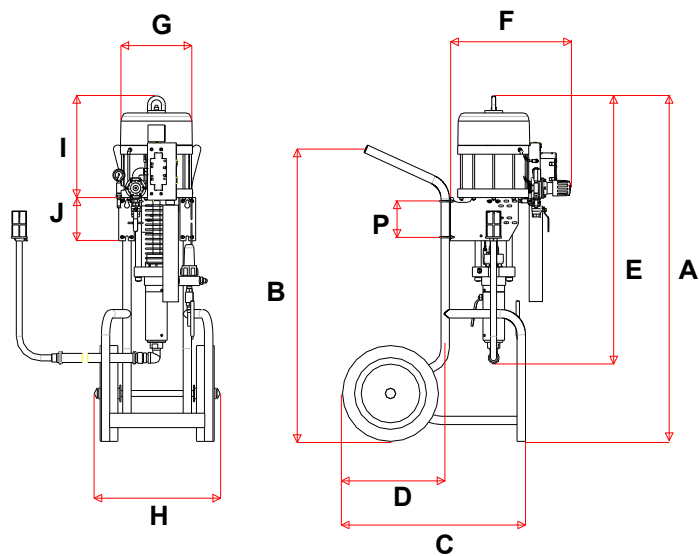

■ DIMENSIONS OF THE PUMP, MODEL 65C260

Ind.	mm	"	Ind.	mm	"	Ind.	mm	"
A	1480	58.27	B	1165	45.86	C	725	28.54
D	390	15.35	E	1160	45.67	F	575	22.64
G	Ø 380	Ø	H	530	20.86	I	470	18.50
J	180	7.08	K	485	19.10			

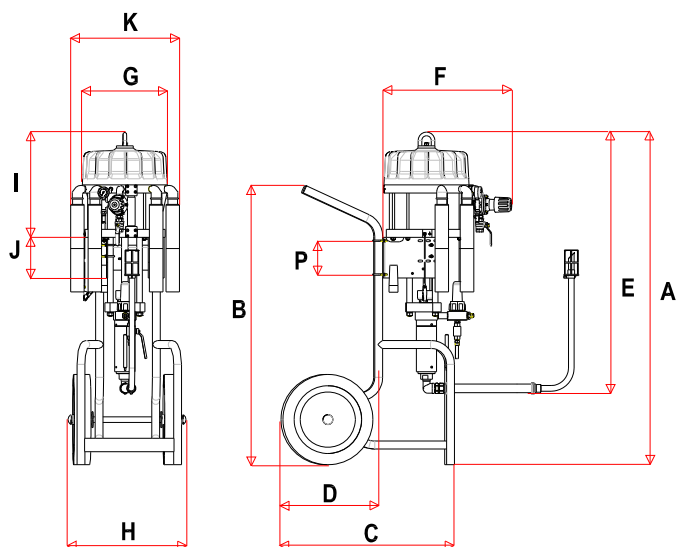

▪ WALL MOUNTED BRACKET OF THE PUMP

Ind.	mm	"	Ind.	mm	"	Ind.	mm	"
L	288	11.34	M	107.5	4.23	N	251	9.9
O	321	12.64	P	150	5.90	Q	70	2.75
R	35	1.38	S	17	0.67	T	15	0.59
U	7 x 15	0.27 x 0.59	V	∅ 11	∅ 0.43 - 7/16	W	∅ 22	∅ 0.87 - 7/8
X	∅ 11	∅ 0.43 - 7/16	Y	18	0.71			

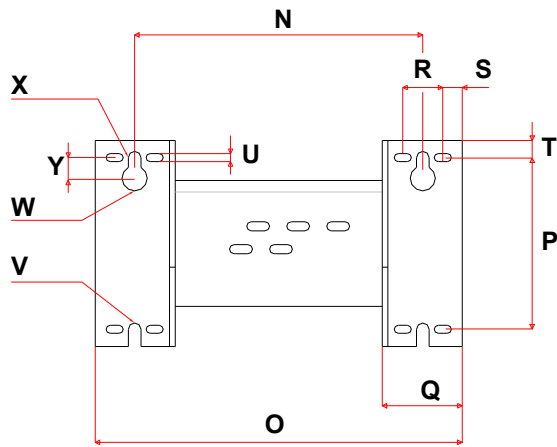

Front view

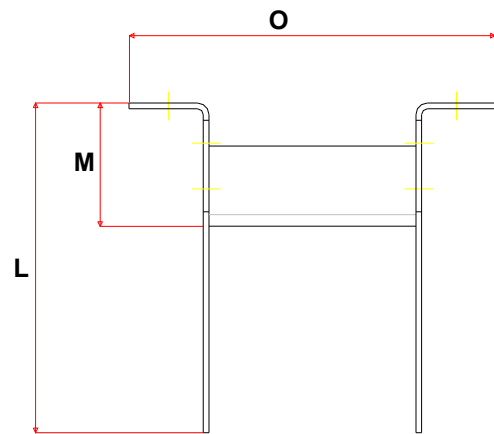

Above view

### 3. INSTALLATION

The pumps are designed to be installed in a spray booth.

#### ▪ DESCRIPTION OF THE LABEL MARKING

Marking in accordance with the ATEX regulation

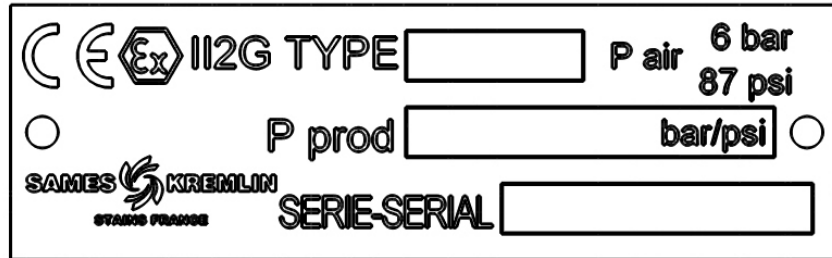

<b>SAMES KREMLIN STAINS FRANCE</b>	Name and address of the manufacturer
<b>TYPE xx</b>	Pump model
<b>CE</b> <b>II 2 G</b>	<b>CE</b> : European conformity  : For use in explosive area <b>II</b> : group II <b>2</b> : class 2 <b>G</b> : gas Surface equipment meant to an area where explosive atmospheres due to gas, vapours, mists are liable to appear from time to time in usual operating.
<b>P prod : xx bar / xx psi</b>	Maximum fluid pressure at the pump outlet
<b>P air : 6 bar / 87 psi</b>	Air supply maximum pressure of the pump motor
<b>Serie / Serial</b>	Number given by SAMES KREMLIN. The 2 first numbers indicate the manufacturing year.

#### ▪ TEMPERATURE CLASS

<b>Temperature class</b>
T3

■ INSTALLATION DIAGRAM

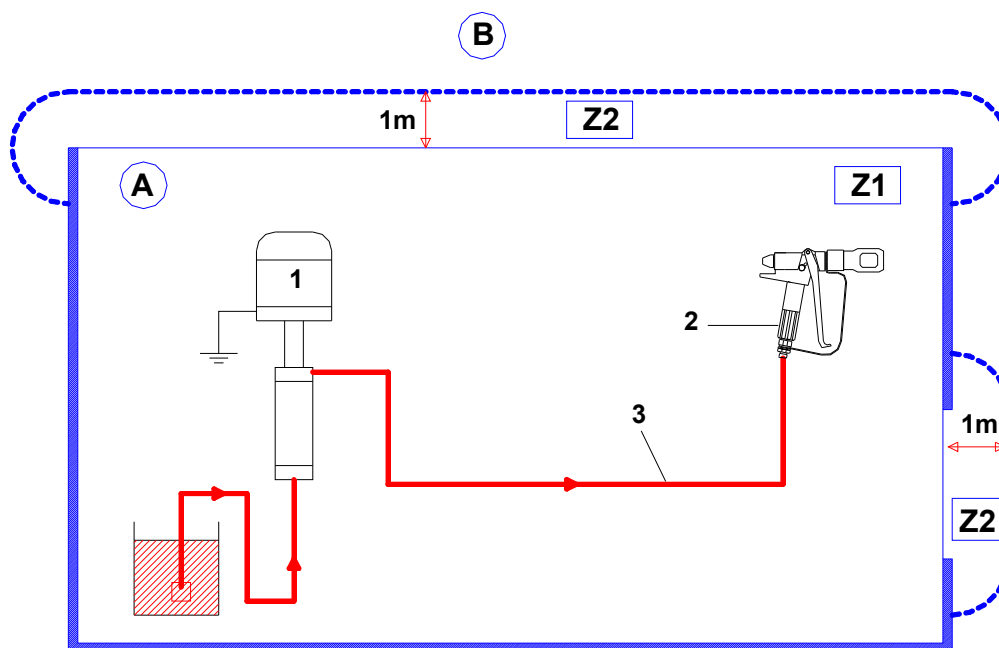

Ind.	Description
A	Explosive area : Area 1 (Z1) or Area 2 (Z2) : spray booth
B	Non explosive area

Ind.	Description
1	Pump
2	Gun
3	Conductive Airless hose



The 1 m / 39.37" distance indicated in these diagrams is given for information purposes only and hold harmless to SAMES KREMLIN. The user is responsible for the extraction and conditioning of the painting area where the equipment is used, for working conditions (refer to EN 60079-10 standard). The 1 m / 39.37" distance may be modified if trials carried out by the user deem this necessary.



**NB:** Choose the appropriate pump to ensure that the working pressure supplied is suitable for the selected gun.