

DOCUMENTATION

PUMP 20C100 / 20C100 T

AIRMIX[®]

Manual : 582.033.110-UK - 2106

Date : 14/06/21

Supersede : 21/12/20

Modif.: Update

TRANSLATION FROM THE ORIGINAL MANUAL

IMPORTANT : Before assembly and start-up, please read and clearly understand all the documents relating to this equipment (professional use only).

THE PICTURES AND DRAWINGS ARE NON CONTRACTUAL. WE RESERVE THE RIGHT TO MAKE CHANGES WITHOUT PRIOR NOTICE.

SAMES KREMLIN SAS

13, chemin de Malacher
38 240 - MEYLAN - France
 : 33 (0)4 76 41 60 60

www.sames-kremlin.com



<p align="center">FR</p> <p><u>Pour une utilisation sure, Il est de votre responsabilité de :</u></p> <ul style="list-style-type: none"> • Lire attentivement tous les documents avant la mise en service de l'équipement, • D'installer, d'utiliser, d'entretenir et de réparer l'équipement conformément aux préconisations de SAMES KREMLIN ainsi qu'aux réglementations nationales et/ou locales, • Vous assurez que les utilisateurs de cet équipement ont été formés, ont parfaitement compris les règles de sécurité et qu'ils les appliquent. 	<p align="center">UK</p> <p><u>To ensure safe use of the machinery, it is your responsibility to:</u></p> <ul style="list-style-type: none"> • Carefully read all documents before putting the machinery into service, • Install, use, maintain and repair the machinery in accordance with SAMES KREMLIN's recommendations and national and/or local regulations, • Make sure that the users of the machinery have received proper training and that they have perfectly understood the safety rules and apply them. 	<p align="center">DE</p> <p><u>Eine sichere Nutzung setzt voraus, dass Sie: :</u></p> <ul style="list-style-type: none"> • Lesen Sie alle Dokumente sorgfältig durch, bevor Sie die Anlage in Betrieb nehmen, • die Anlage im Einklang mit den Empfehlungen von SAMES KREMLIN sowie mit den nationalen und/oder lokalen Bestimmungen installieren, verwenden, warten und reparieren, • sich vergewissern, dass die Nutzer dieser Anlage angemessen geschult wurden, die Sicherheitsbestimmungen verstanden haben und sie anwenden.
<p align="center">ES</p> <p><u>Para una utilización segura, será de su responsabilidad:</u></p> <ul style="list-style-type: none"> • leer atentamente todos los documentos antes de la puesta en servicio del equipo, • instalar, utilizar, efectuar el mantenimiento y reparar el equipo con arreglo a las recomendaciones de SAMES KREMLIN y a la normativa nacional y/o local, • cerciorarse de que los usuarios de este equipo han recibido la formación necesaria, han entendido perfectamente las normas de seguridad y las aplican. 	<p align="center">IT</p> <p><u>Per un uso sicuro, vi invitiamo a:</u></p> <ul style="list-style-type: none"> • leggere attentamente tutta la documentazione prima della messa in funzione dell'apparecchio, • installare, utilizzare, mantenere e riparare l'apparecchio rispettando le raccomandazioni di SAMES KREMLIN, nonché le normative nazionali e/o locali, • accertarvi che gli utilizzatori dell'apparecchio abbiano ricevuto adeguata formazione, abbiano perfettamente compreso le regole di sicurezza e le applichino. 	<p align="center">PT</p> <p><u>Para uma utilização segura, é da sua responsabilidade:</u></p> <ul style="list-style-type: none"> • Ler atentamente todos os documentos antes de pôr o equipamento em funcionamento, • Proceder à instalação, utilização, manutenção e reparação do equipamento de acordo com as preconizações de SAMES KREMLIN, bem como com outros regulamentos nacionais e/ou locais aplicáveis, • Assegurar-se que os utilizadores do equipamento foram devidamente capacitados, compreenderam perfeitamente e aplicam as devidas regras de segurança.
<p align="center">NL</p> <p><u>Voor een veilig gebruik dient u:</u></p> <ul style="list-style-type: none"> • Lees alle documenten zorgvuldig door voordat u de apparatuur in gebruik neemt, • het apparaat te installeren, gebruiken, onderhouden en repareren volgens de door SAMES KREMLIN gegeven aanbevelingen en overeenkomstig de nationale en/of plaatselijke reglementeringen, • zeker te stellen dat de gebruikers van dit apparaat zijn opgeleid, de veiligheidsregels perfect hebben begrepen en dat zij die ook toepassen. 	<p align="center">SE</p> <p><u>För en säker användning av utrustningen ansvarar ni för följande:</u></p> <ul style="list-style-type: none"> • Läs alla dokument noggrant innan utrustningen tas i bruk, • Läs Installera, använd, underhåll och reparera utrustningen enligt anvisningarna från SAMES KREMLIN och enligt nationella och/eller lokala bestämmelser. • Försäkra er om att användare av denna utrustning erhållit utbildning, till fullo förstått säkerhetsföreskrifterna och tillämpar dem. 	<p align="center">FI</p> <p><u>Käytön turvallisuuden varmistamiseksi velvollisuutesi on:</u></p> <ul style="list-style-type: none"> • Lue kaikki asiakirjat huolellisesti ennen laitteen käyttöönottoa. • Noudattaa laitteiston asennuksessa, käytössä, kunnossapidossa ja huollossa SAMES KREMLIN in suosituksia sekä kansallisia ja/tai paikallisia määräyksiä, • Varmistaa, että laitteiston käyttäjät ovat koulutettuja ja ymmärtävät täysin turvallisuusmääräykset ja miten niitä sovelletaan.
<p align="center">PL</p> <p><u>Dla zapewnienia bezpiecznego użytkowania na użytkownika spoczywa obowiązek:</u></p> <ul style="list-style-type: none"> • Przed uruchomieniem urządzenia należy dokładnie przeczytać wszystkie dokumenty, • Instalowania, użytkowania, konserwacji i naprawy urządzenia zgodnie z zaleceniami firmy SAMES KREMLIN oraz z przepisami miejscowymi, • Upewnienia, że wszyscy przeszkoleni użytkownicy urządzenia zrozumieli zasady bezpieczeństwa i stosują się do nich. 	<p align="center">CS</p> <p><u>Pro bezpečné používání jste povinni:</u></p> <ul style="list-style-type: none"> • Před uvedením zařízení do provozu si pečlivě přečtete všechny dokumenty, • Nainstalovat, používat, udržovat a opravovat zařízení v souladu s pokyny firmy SAMES KREMLIN a s národními a/nebo místními legislativními předpisy, • Ujistit se, že uživatelé tohoto zařízení byli vyškoleni, že dokonale pochopili bezpečnostní pravidla a že je dodržují. 	<p align="center">SL</p> <p><u>Za varno uporabo ste dolžni:</u></p> <ul style="list-style-type: none"> • pred začetkom uporabe opreme natančno preberite vse dokumente, • instalirati, uporabljati, vzdrževati in popravljati opremo po določilih SAMES KREMLIN in v skladu z veljavnimi nacionalnimi in/ali lokalnimi predpisi, • poskrbeti, da so uporabniki te opreme ustrezno usposobljeni, poznajo varnostne predpise in da jih upoštevajo.
<p align="center">SK</p> <p><u>V záujme bezpečného je vašou povinnosťou:</u></p> <ul style="list-style-type: none"> • pred uvedením zariadenia do prevádzky si pozorne prečítajte všetky dokumenty, • nainštalovať, používať, udržiavať a opravovať zariadenie v súlade s odporúčaniami spoločnosti SAMES KREMLIN a národnými a/alebo miestnymi predpismi, • uistiť sa, že používatelia tohto zariadenia boli zaškolení, riadne porozumeli pravidlám bezpečnosti a používajú ich. 	<p align="center">HU</p> <p><u>A biztonságos használat érdekében az Ön felelőssége, hogy:</u></p> <ul style="list-style-type: none"> • Olvassa el figyelmesen az összes dokumentumot, mielőtt a berendezést üzembe helyezi, • a berendezést a SAMES KREMLIN ajánlásainak valamint a nemzeti és/vagy helyi szabályozásoknak megfelelően helyezze üzembe, használja, tartsa karban és javítsa, • megbizonyosodjon róla, hogy a berendezés felhasználói képzettek, tökéletesen megértették és alkalmazzák a biztonsági előírásokat. 	<p align="center">RO</p> <p><u>Pentru o utilizare sigură, este responsabilitatea dvs. să:</u></p> <ul style="list-style-type: none"> • Citiți cu atenție toate documentele înainte de a pune echipamentul în funcțiune, • Instalați, utilizați, întrețineți și reparați echipamentul conform instrucțiunilor SAMES KREMLIN precum și reglementărilor naționale și/sau locale, • Vă asigurați că utilizatorii acestui echipament au fost instruiți, au înțeles perfect regulile de securitate și le aplică integral.

Déclaration(s) de conformité au verso de ce document / Declaration(s) of conformity at the back of this document / Konformitätserklärung(en) auf der Rückseite dieser Unterlage / Declaración (es) de conformidad en el reverso de este documento / Dichiarazione/i di conformità sul retro del presente documento / Declaração(ções) de conformidade no verso do documento / Conformiteitsverklaring(en) op de keerzijde van dit document / Försäkran om överensstämmelse på omstående sida av detta dokument / Vaatimustenmukaisuusvakuutukset tämän asiakirjan kääntöpuolella / Deklaracja(e) zgodności na odwrocie dokumentu / Prohlášení o shodě se nachází/nacházejí na zadní straně tohoto dokumentu / Deklaracija(e) o skladnosti na hrbtini strani tega dokumenta / Vyhlásenie/-a o zhode sa nachádzajú na zadnej strane dokumentu / A dokumentum hátlapján szereplő megfelelőségi nyilatkoz(ok) / Declarații de conformitate pe versoul acestui document



DECLARATION UE DE CONFORMITE
EU DECLARATION OF CONFORMITY
EU- KONFORMITÄTSERKLÄRUNG
DECLARACIÓN UE DE CONFORMIDAD
DICHIARAZIONE DI CONFORMITÀ UE
DECLARAÇÃO UE DE CONFORMIDADE
EU-CONFORMITEITSVERKLARING
EU-FÖRSÄKRAN OM ÖVERENSSTÄMMELSE
EU- VAATIMUKSENMUKAISUUSVAKUUTUS
DEKLARACJA ZGODNOŚCI UE
EU PROHLÁŠENÍ O SHODĚ
IZJAVA EU O SKLADNOSTI
VYHLÁSENIE O ZHODE
EU-MEGFELELŐSÉGI NYILATKOZAT
DECLARAȚIA DE CONFORMITATE UE

Le fabricant / The manufacturer / Der Hersteller / El fabricante / Il produttore / O fabricante / De fabrikant / Tillverkare / Valmistaja / Producent / Výrobce / Proizvajalec / Výrobca / Gyártó / Fabricantul:	SAMES KREMLIN SAS 13, chemin de Malacher 38 240 - MEYLAN - FRANCE Tél. : 33 (0)4 76 41 60 60
---	--

Déclare que le matériel désigné ci-après / Herewith declares that the equipment / erklärt hiermit, dass die / Declara que el material designado a continuación / Dichiaro che il materiale sottoindicato / Declara que o material a seguir designado / verklaart dat de hieronder aangeduide apparatuur / Kungör att den utrustning som anges här nedan / ilmoittaa, että alla mainitut laitteistot / Oświadczam, że wymienione poniżej urządzenia / Prohlašuje, že níže uvedené vybavení / Izjavlja, da je opisana oprema spodaj / Vyhlasuje, že zariadenie uvedené nižšie / Kijelenti, hogy a megjelölt anyag a továbbiakban / Declară că echipamentul precizat mai jos:

POMPE INTENSIVE™ BASSE ET MOYENNE PRESSION POUR APPLICATION PNEUMATIQUE ET AIRMIX®
A MOTEUR AVEC INVERSEUR / INTENSIVE™ AIRMIX® & LOW PRESSURE PUMP - AIR MOTOR WITH
REVERSING BLOCK / INTENSIVE™ AIRMIX® PNEUMATISCHE PUMPE MIT UMSTEUERMOTOR
/ BOMBA NEUMÁTICA INTENSIVE™ Y BOMBA AIRMIX® INTENSIVE™ CON MOTOR CON INVERSOR

20C100	20C100 T
--------	----------

Est conforme à la législation d'harmonisation de l'Union applicable suivante / Is in conformity with the relevant Union harmonisation legislation / Erfüllt die einschlägigen Harmonisierungsrechtsvorschriften der Union / es conforme con la legislación de armonización pertinente de la Unión / è conforme alla pertinente normativa di armonizzazione dell'Unione / in overeenstemming met de desbetreffende harmonisatiewetgeving van de Unie / med den relevanta harmoniserade unionslagstiftningen / on asiaa koskevan unionin yhdenmukaistamisläisäädännön vaatimusten mukainen / jest zgodny z odpowiednimi wymaganiami unijnego prawodawstwa harmonizacyjnego / Shoduje se s následující příslušnou evropskou harmonizační legislativou / V skladu s harmonizirano zakonodajo Unije / Je v súlade s uplatniteľnými harmonizačnými právnymi predpismi EÚ / Megfelel a következő alkalmazandó uniós harmonizációs szabályozásnak / Este conform cu legislația aplicabilă de armonizare de mai jos

Directive ATEX / ATEX Directive / ATEX Richtlinie / Directiva ATEX / Direttiva ATEX / Diretiva ATEX / ATEX-Richtlijn / ATEX-direktivet / ATEX-direktivi / Dyrektywa ATEX / Směrnice ATEX / Direktiva ATEX / Smernica ATEX / ATEX-irányelv	2014/34/UE

La présente déclaration de conformité est établie sous la seule responsabilité du fabricant / This declaration of conformity is issued under the sole responsibility of the manufacturer / Die alleinige Verantwortung für die Ausstellung dieser Konformitätserklärung trägt der Hersteller / La presente declaración de conformidad se expide bajo la exclusiva responsabilidad del fabricante / La presente dichiarazione di conformità è rilasciata sotto la responsabilità esclusiva del fabbricante / A presente declaração de conformidade é emitida sob a exclusiva responsabilidade do fabricante / Deze conformiteitsverklaring wordt verstrekt onder volledige verantwoordelijkheid van de fabrikant / Denna försäkran om överensstämmelse utfärdas på tillverkarens eget ansvar / Tämä vaatimustenmukaisuusvakuutus on annettu valmistajan yksinomaisella vastuulla / Niniejsza deklaracja zgodności wydana zostaje na wyłączną odpowiedzialność producenta / Toto prohlášení o skodě se vydává na výhradní odpovědnost výrobce / Za izdajo te izjave o skladnosti je odgovoren izključno proizvajalec / Toto vyhlásenie o zhode sa vydáva / na vlastnú zodpovednosť výrobcu / Ezt a megfelelőségi nyilatkozatot a gyártó kizárólagos felelőssége mellett adják ti / Prezenta declarație de conformitate este emisă pe răspunderea exclusivă a producătorului.



Hervé WALTER

Directeur Recherche & Développement / Research & Development Director / Direktor für Forschung & Entwicklung / Director de Investigación y Desarrollo / Direttore Ricerca e sviluppo / Director de Pesquisa e desenvolvimento / Manager Onderzoek en Ontwikkeling / Direktör för Forskning och Utveckling / Johtaja tutkimus ja kehitys / Dyrektor ds. Badań i rozwoju / Ředitel výzkumu a vývoje / Direktor za raziskave in razvoj / Riaditeľ pre výskum a vývoj / Kutatási és Fejlesztési Igazgató / Director de cercetare și Dezvoltare

Fait à Meylan, le / Established in Meylan, on / Geschehen zu Meylan, am / En Meylan, a / Redatto a Meylan, / Vastgesteld te Meylan, / Utformat i Meylan, den / Meylan, Ranska, / Sporządzono w Meylan, dnia / Meylan, dnia / V Meylanu, / V Meylan dňa / Kelt Meylanban, / Întocmită la Meylan, pe data de 31/05/2021 - 05/31/2021



INSTALLATION AND SAFETY INSTRUCTIONS

TRANSLATION FROM THE ORIGINAL MANUAL

IMPORTANT : Before assembly and start-up, please read and clearly understand all the documents relating to this equipment (professional use only).

THE PICTURES AND DRAWINGS ARE NON CONTRACTUAL. WE RESERVE THE RIGHT TO MAKE CHANGES WITHOUT PRIOR NOTICE.

SAMES KREMLIN SAS
13, chemin de Malacher
38 240 - MEYLAN - France
☎ : 33 (0)4 76 41 60 60

www.sames-kremlin.com

1. SAFETY INSTRUCTIONS

GENERAL SAFETY INSTRUCTIONS



CAUTION : The equipment can be dangerous if you do not follow our instructions concerning installation and servicing described in this manual and in accordance with applicable European standards and local national safety regulations.

Please carefully read all the instruction literature before operating your equipment.

Only trained operators can use the equipment.

The foreman must ensure that the operator has understood the safety instructions for this equipment as well as the instructions in the manuals for the different parts and accessories.

Read carefully all instruction manuals, label markings before operating the equipment.















Incorrect use may result in injury. This equipment is for professional use only. It must be used only for what it has been designed for. Never modify the equipment. The parts and accessories supplied must be regularly inspected. Defective or worn parts must be replaced.

Guards (motor cover, coupling shields, connectors,...) have been designed for a safe use of the equipment.
The manufacturer will not be held responsible for bodily injury or failure and / or property damage due to destruction, the overshadowing or the partial or total removal of the guards.

Never exceed the equipment components' maximum working pressure.

Comply with regulations concerning safety, fire risks, electrical regulations in force in the country of final destination of the material. Use only products or solvent compatible with the parts in contact with the material (refer to data sheet of the material manufacturer).

PICTOGRAMS

					
NIP HAZARD	WARNING MOVING ELEVATOR	WARNING MOVING PARTS	WARNING MOVING SHOVEL	DO NOT EXCEED THIS PRESSURE	HIGH PRESSURE HAZARD
					
RELIEF OR DRAIN VALVE	WARNING HOSE UNDER PRESSURE	WEAR GLASSES OBLIGATORY	WEAR OF GLOVES IS OBLIGATORY	PRODUCT VAPOR HAZARDS	WARNING HOT PARTS OR AREAS
					
ELECTRICAL HAZARD	WARNING FIRE HAZARDS	EXPLOSION HAZARDS	GROUNDING	WARNING (USER)	WARNING SERIOUS INJURIES

PRESSURE HAZARDS



Current legislation requires that an **air relief valve** be fitted in the air supply circuit to the air motor to prevent over pressurisation. This safety feature, ensures that it is not possible to supply the air motor with excessive air pressure that may cause injury.

Please ensure that a **material drain valve** is fitted in the fluid circuit to drain and depressurise the circuit. Once depressurised and drained, work /servicing may then commence on the equipment. Please remember to close these valves when restarting the system.

HIGH PRESSURE INJECTION HAZARDS



When working with high pressure equipment, special care is required. Fluid leaks can occur. There is a risk of material being injected to any exposed parts of body, this could cause severe injury :

- medical care must be sought immediately if paint is injected under the skin or in other parts of the body (eyes, fingers).
- never point the spray gun at any one. Never try to stop the spray with your hands or fingers nor with rags or similars.
- **follow the shut down procedure and always depressurize air and fluid circuits** before carrying out any servicing on the gun (cleaning, checking, maintenance of the material or cleaning of the gun nozzles).
- for the guns equipped with a safety device, always lock the trigger when not in use.

FIRE - EXPLOSION - SPARKS - STATIC ELECTRICITY HAZARDS

A poor earth connection, inadequate ventilation, sparks or static electricity can cause an explosion or fire. to avoid these risks when using or servicing SAMES KREMLIN equipment, the following safety procedures must be followed :



- ensure a good earth connection and ground the parts to be handled i.e. solvents, materials, components and equipment,
- ensure adequate ventilation,
- keep working area clean and free from waste solvents, chemicals, or solid waste i.e. rags, paper and empty chemicals drums,
- never use electrical switches / power if in an atmosphere of volatile solvent vapour,
- stop working immediately in case of electrical arcs,
- never store chemicals and solvents in the working area.
- use paint whose flash point is the highest possible to prevent from any formation of gas and inflammable vapours (refer to materials' safety instructions),
- install a cover on the drums to reduce the diffusion of gas and vapours in the spraybooth.

TOXIC PRODUCT HAZARDS



Toxic products or vapours can cause severe injury not only though contact with the body, but also if the products are ingested or inhaled. It is imperative :

- to know the material products and their risks,
- notified or hazardous materials must be stored in accordance with the regulations,
- the material must be stored in an appropriate container, never place materials in a container where there is a risk of spillage or leakage,
- a procedure must be applied for the safe disposal of waste material. It must comply with all prevailing regulations and legislations of the country where the equipment is to be used,
- protective clothing should always be worn in compliance with the material manufacturers' recommendations,
- depending on the application and chemical safety instructions, safety glasses, hearing protective earplug, gloves, foot wear, protective masks and possible breathing equipment should be worn to comply with the regulations (Refer to chapter "Safety equipment of SAMES KREMLIN selection guide).



CAUTION!

It is forbidden to use material containing high concentrations of halogenated hydrocarbon solvents with **aluminium** or **zinc fillers**. Non-compliance with the instructions may cause explosion risk causing serious or fatal injury.



EQUIPMENT REQUIREMENTS

Guards (motor cover, coupling shields, connectors,...) have been designed for a safe use of the equipment.

The manufacturer will not be held responsible for bodily injury or failure and / or property damage due to destruction, the overshadowing or the partial or total removal of the guards.

PUMP



Before carrying out any work, it is imperative to read and clearly understand the disassembly and reassembly instructions before servicing. The operator must understand the equipment and the safety instructions. These instructions are available in the equipment manuals.



The air motor is designed to be mounted with a pump. Never modify any components or couplings. When operating, please keep hands away from moving parts. Before starting up the equipment, please read the PRESSURE RELIEF instructions. Please ensure that any relief or drain valves fitted are in good working order.

HOSES

- Keep hoses out of circulation areas, moving parts or hot surfaces,
- Never expose product hoses to temperature higher than + 60°C / 140° F or lower than 0°C / 32° F,
- Never pull or use the hoses to move the equipment,
- Tighten all fittings as well as the hoses before operating the equipment,
- Check the hoses regularly; change them if they are damaged,
- Never exceed the maximum working pressure (MWP) indicated on the hose.

USED PRODUCTS

Considering the wide variety of products that are available and can be used in our equipment it is impossible to check and make recommendations for all chemical data, regarding the risks of possible chemical attack and their long term chemical reaction

SAMES KREMLIN can not be held liable for :

- compatibility of wetted parts,
- risks to staff and the surroundings,
- for worn or defective parts, for faulty equipment or units, or the quality of final product.

It is the responsibility of the user to know and prevent any possible risks such as toxic vapours, fires or explosions. He shall determine the risks of immediate reactions or pursuant to repeated exposures of the staff,

SAMES KREMLIN shall not be liable for physical injuries, direct or indirect material damages caused by the use of chemicals.

2. HANDLING

 **Check the weight and the dimensions of the equipment**
(☞ refer to 'Technical features' section of the instruction manual)

If weight and dimensions are too important, the unloading must be carried out by means of a forklift or any other appropriate means with a qualified personnel and in a clear horizontal area to prevent from risks of damage injury or an accident.

The centre of gravity is not in the centre of the machine : carry out by hand a stability-test after having lifted the whole at 10 cm / 3.937" maximum.

After the unloading, the handling of the whole (eg: elevator pump) is carried out by means of a pallet truck taking the bottom part of the frame.

Remark : Each pump motor is fitted with a ring. The ring is designed for the hoisting of one pump and can not be used for the handling of the complete assembly.

3. STORING

Storing before installation :

- Storing ambient temperature : 0 / +50 °C / 0 / +122°F
- Protect the whole against dust, water trickling, dampness and shocks.

Storing after installation :

- Operating temperature : +15 / +35 °C / +59 / +138.2° F
- Protect the whole against dust, water trickling, dampness and shocks.

4. INSTALLATION OF THE EQUIPMENT

The machine is installed on a stable horizontal floor (for eg a concrete flag).

The machine shall be made stable by the use of holding down bolts or by the use of other anchoring methods, strong enough to prevent unintended bodily movement of the equipment.



To avoid risks caused by static electricity, the equipment as well as its components must be grounded.

- **For the pumping equipments** (pumps, pneumatic rams, frame...), a section wire of 2.5 mm² is fixed on the material. Use this wire to connect the material to "the general ground". In case of severe environments (mechanical protection of the wire of earthing insufficient, vibrations, mobile material...) where function damages at the ground are probable, the user have to replace the provided wire of 2.5 mm² by a device more adapted to its environment (wire with a more important section, bonding strip, fixing by thimble with eyelet...).

The continuity of the ground must be controlled by a qualified electrician. If the continuity of the ground is not ensured, check the terminal, the wire and the earthing point. **Never** use the material without have solved this problem.

- In the severe cases of environments (mechanical protection of the wire of earthing insufficient, vibrations, mobile material...) where damages of the function put at the ground are probable, the user will have to replace the wire of 2.5 mm² provided, by a device more adapted to its environment (wire of more important section, bonding strip, fixing by thimble with eyelet...),
- **The gun** must be 'grounded' via a material hose or an air hose. In case of spraying by means of a gun with cup, the air hose must be conductive,
- **The materials to be painted** must also be grounded.

All the materials situated in the working area shall be grounded.



- **Never store** more than necessary inflammable materials inside the working area,
- The materials must be stored into **approved drums** and grounded,
- Use only grounded **metals containers** for the use of cleaning solvents,
- **Cardboard and paper are prohibited.**

5. MARKING OF THE EQUIPMENT



Each equipment has a label plate with the name of the manufacturer, the equipment part number, the interesting informations to use correctly the equipment (pressure, voltage,...) and sometimes the above pictogram.

The equipment is designed with and consists of high quality materials and components which can be re-used.

The 2012/19/UE European Directive covers all equipments with a crossed-out bin pictogram. Please inform yourself about the collection systems for electric and electronic equipments.

Please act in accordance with local rules and **do not dispose of old equipment with household wastes**. A correct disposal of old equipment will help prevent negative consequences for the environment and health.

STAINLESS STEEL

AIRMIX® PUMPS

20C100
20C100 T

Disassembly / Reassembly

TRANSLATION FROM THE ORIGINAL MANUAL

IMPORTANT : Before assembly and start-up, please read and clearly understand all the documents relating to the equipment (professional use only).

THE PICTURES AND DRAWINGS ARE NOT CONTRACTUAL. WE RESERVE THE RIGHT TO MAKE CHANGES WITHOUT PRIOR NOTICE.

SAMES KREMLIN SAS
13, chemin de Malacher
38 240 - MEYLAN - France
☎ : 33 (0)4 76 41 60 60

www.sames-kremlin.com



CAUTION :

Before any action on the pump, shut off the compressed air supply and depressurize the system.

The pump is manufactured under the ATEX agreement and can not be modified. SAMES KREMLIN will not be held responsible for any failure to comply with that instruction.

**Guards (air motor cover, coupling shields, housings ...) have been designed for safe use of the equipment.
The manufacturer will not be held responsible for bodily injury or failure and / or damage to property due to removal or partial removal of the guards.**

▪ **SUCTION VALVE (DOC. 573.080.050)**

Unscrew suction valve (5) by holding cylinder (2).

The ball (10a / 10b) is secured on the valve (5) by means of a circlips (9).

Clean the parts.

Reinstall suction valve (5) and seal (25). Replace them if necessary.

▪ **EXHAUST VALVE AND MOBILE PACKING**

Unscrew cylinder (2) and pull it downwards.

Unscrew exhaust valve (6) by holding piston (3).

Remove ball (17a / 17b), washer (12a / 12b) and seal (13a / 13b / 13c).

Clean the parts.

Remount the parts in reverse order.

For that :

- Install seal (13a / 13b / 13c), washer (12a / 12b) and ball (17a / 17b) onto exhaust valve (6).
- Screw exhaust valve (6) into the piston (3). The seal must be blocked by screwing exhaust valve (6) strongly.

If necessary replace seal (8) when reinstalling cylinder (2).

■ **UPPER PACKING**

Separate motor piston rod from hydraulic piston (3).

Unscrew wetting-cup (4) by means of the wrench supplied with the pump.

Pull piston (3) upwards to remove upper packing seals (21 and 22a / 22b) or the upper packing (18a / 18b).

Reinstall parts in reverse order. Be certain seals (21 and 22a / 22b) or upper packing (18a / 18b) are installed properly (**direction**, **order** and assembly **dimension**).

Tighten wetting-cup (4).

After reassembly, fill up the pump with solvent and increase pressure to maximum in the fluid section. Then stop the pump and open exhaust valve to depressurize.

Retighten wetting-cup (4) by means of the wrench in order to be in accordance with the opposite drawing.

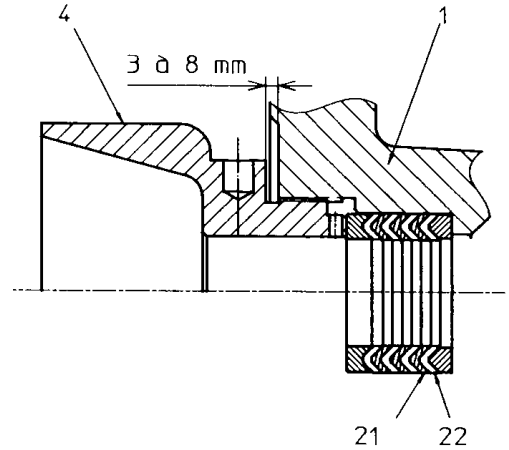

■ **REVERSING BLOCK (REFER TO DOC. 573.087.040)**

**Guards (air motor cover, coupling shields, housings ...) have been designed for safe use of the equipment.
The manufacturer will not be held responsible for bodily injury or failure and / or damage to property due to removal or partial removal of the guards.**

Disassemble cover (32) by removing the 3 CHc screws (33).

Dissociate female yoke (12) from reversing block lever (9).

Dismount reversing block by removing screws (10 and 8).

Reinstall the new reversing block in the reverse order of the disassembly sequence.

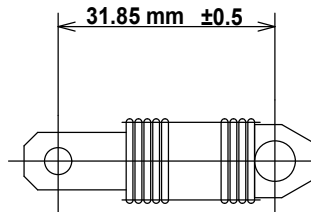

⇒ **CAUTION :** The number of spirals must equally be distributed on each fastening parts in order to get the above dimension.

Before reassembling :

- Clean the parts with the appropriate cleaning solvent.
- Install new seals if it is necessary after having lubricated them with PTFE grease.
- Install new parts if it is necessary.

▪ ASSEMBLY INSTRUCTIONS

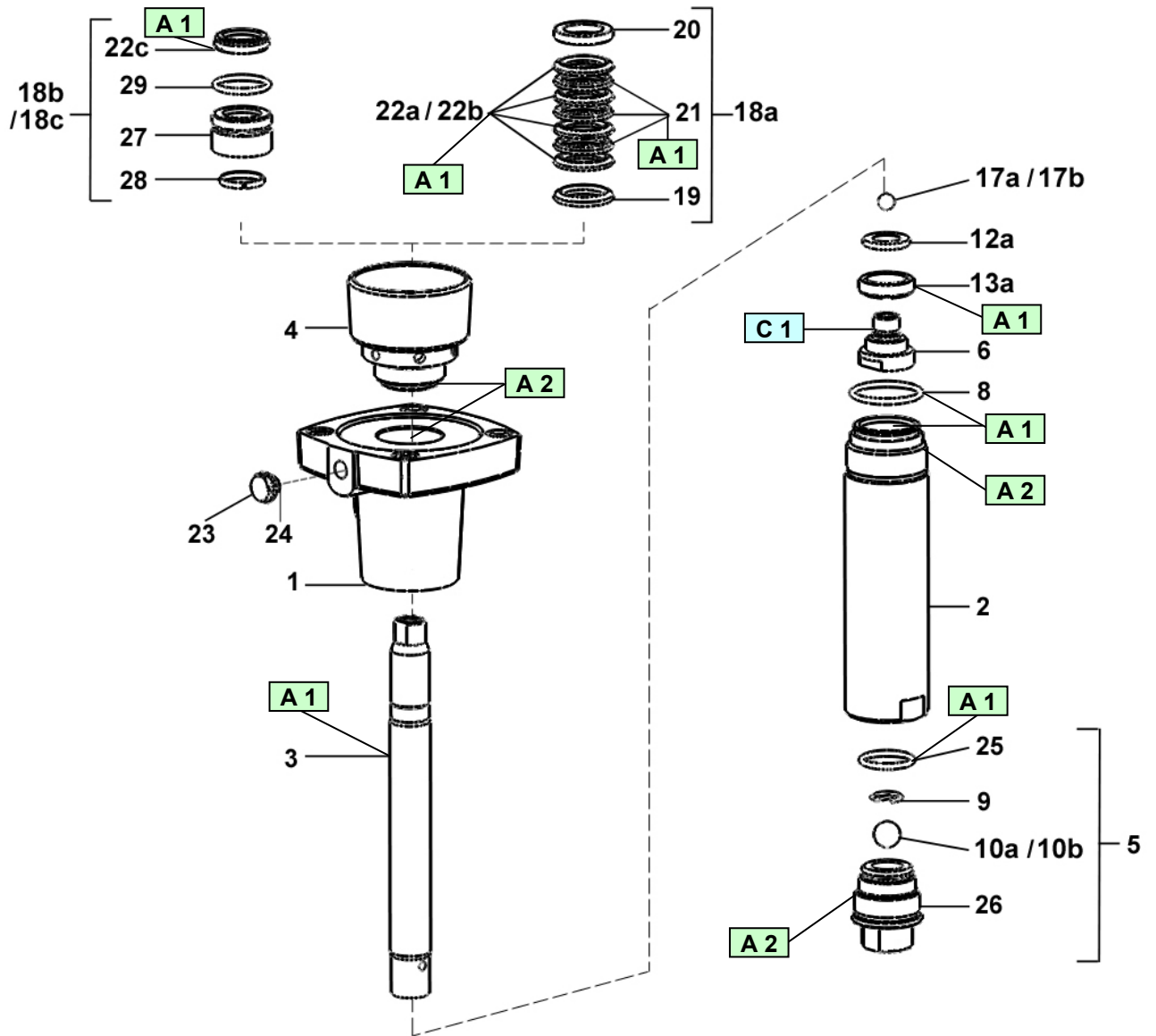

For mobile packing with chevron seals

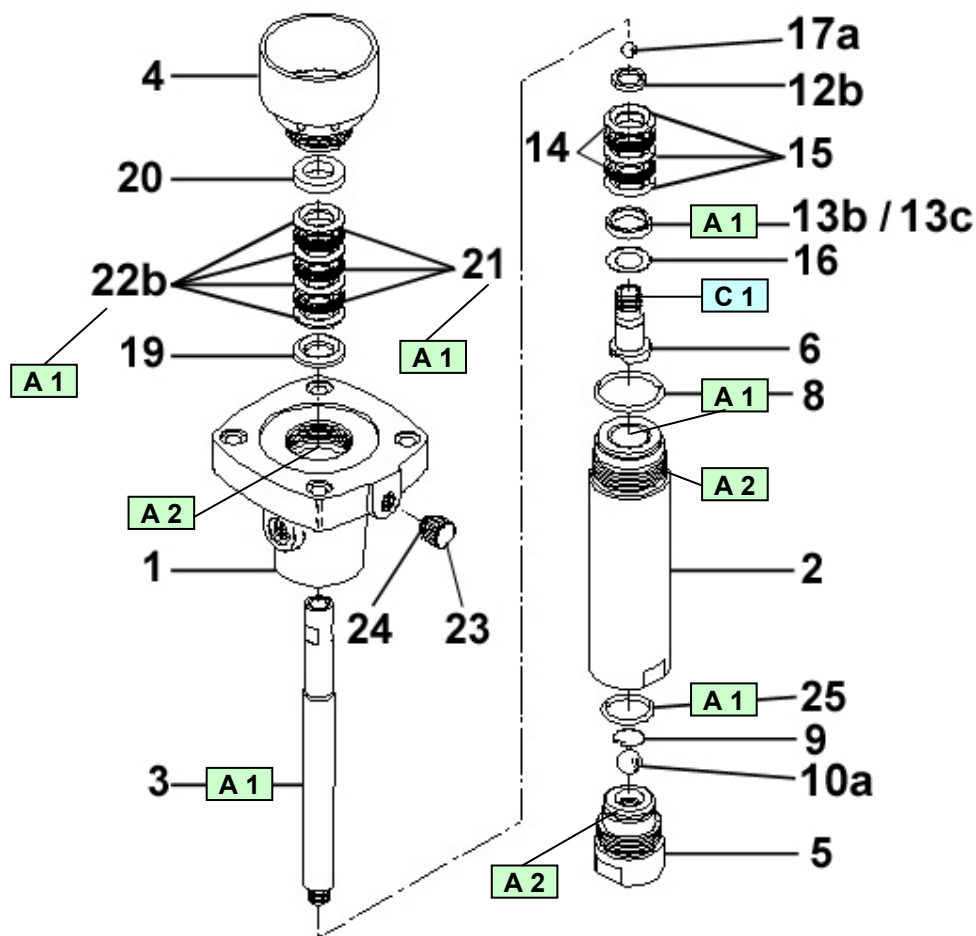

Index	Instruction	Description	Part number
A 1	PTFE grease	PTFE grease (10 ml / 0.3 oz)	560.440.101
A 2	Anti-seize grease	Grease box (450 g / 0.99 lb)	560.420.005
C 1	Medium strength Aneorobic Pipe sealant	Loctite 5772 (50 ml / 1.7 oz)	554.180.015

<p>Doc. 573.081.050 Date/Datum/Fecha : 13/04/21 Annule/Cancel/ Ersetzt/Anula : 21/12/20</p>	<p>Modif. / Änderung : Mise à jour / Update / Aktualisierung / Actualización</p>	<p>Pièces de rechange Spare parts list Ersatzteilliste Piezas de repuesto</p>
---	---	--

<p>POMPE AIRMIX®, modèle 20C100 et modèle 20C100 T (turbo)</p>	<p>AIRMIX® PUMP, model 20C100 and model 20C100 T (turbo)</p>
<p>AIRMIX® PUMPE, Modell 20C100 und Modell 20C100 T (Turbo)</p>	<p>BOMBA AIRMIX®, tipo 20C100 y tipo 20C100 T (turbo)</p>

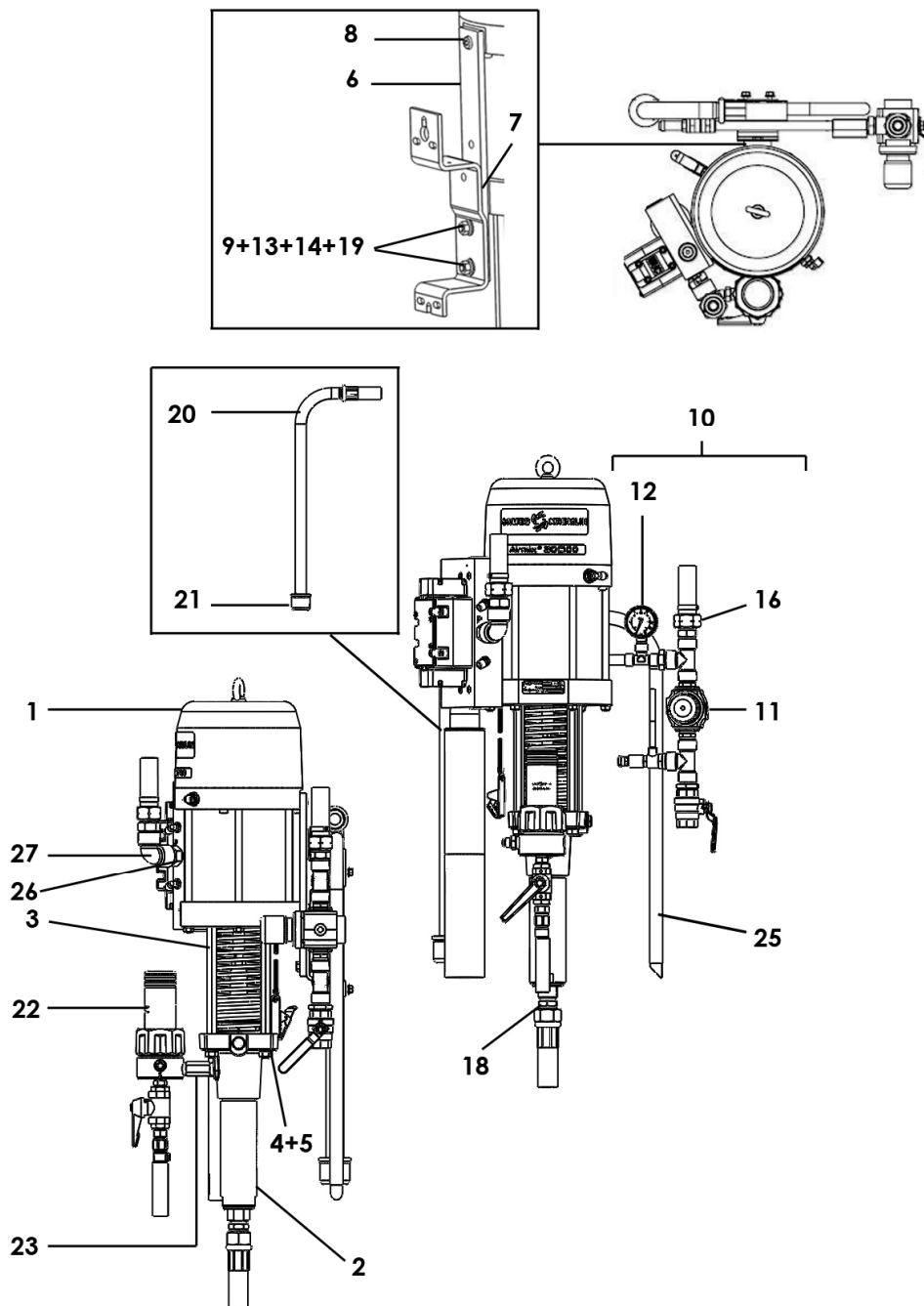

POMPE MURALE, modèle 20C100 sans filtre, avec canne d'aspiration	WALL MOUNTED PUMP, model 20C100 without filter, with suction rod	# 151.780.100
WANDANLAGE, Modell 20C100 ohne Filter, mit Saugschlauch	BOMBA MURAL, tipo 20C100 sin filtro, con caña de aspiración	

Ind	#	Désignation	Description	Bezeichnung	Denominación	Qté
-	151 780 000	Pompe 20C100 nue	Bare pump, model 20C100	Pumpe 20C100, nackt	Bomba sola, tipo 20C100	1
*1	146 275 000	▪ Moteur 1000-4 (voir Doc. 573.045.050)	▪ Air motor, model 1000-4 (refer to Doc. 573.045.050)	▪ Luftmotor 1000-4 (siehe Dok. 573.045.050)	▪ Motor, tipo 1000-4 (consultar Doc. 573.045.050)	1
*2	144 960 000	▪ Hydraulique C100 (voir Doc. 573.080.050)	▪ Fluid section, model C100 (refer to Doc. 573.080.050)	▪ Hydraulikteil C100 (siehe Dok. 573.080.050)	▪ Hidráulica, tipo C100 (consultar Doc. 573.080.050)	1
3	051 770 001	▪ Tirant	▪ Tie-rod, connecting	▪ Bolzen	▪ Tirante	4
4	953 010 021	▪ Ecrou HM 10	▪ Nut, HM 10	▪ Mutter HM 10	▪ Tuerca HM 10	4
5	963 040 021	▪ Rondelle MN 10	▪ Washer, MN 10	▪ Scheibe MN 10	▪ Arandela MN 10	4
-	050 311 902	▪ Ressort de protection	▪ Protective spring	▪ Feder	▪ Muelle de protección	1
*	151 775 010	Ensemble fixation	Mounting assembly	Montageplatte kpl.	Conjunto de fijación	1
6	051 770 101	▪ Plaque d'interface	▪ Plate	▪ Befestigungsplatte	▪ Placa	1
7	933 011 279	▪ Vis H 8 x 20	▪ Screw, model H 8 x 20	▪ Schraube M 8 x 20	▪ Tornillo, tipo H 8 x 20	1
8	933 151 147	▪ Vis CHc M 8 x 10	▪ Screw, model SHC M 8 x 10	▪ Schraube CHc M 8 x 10	▪ Tornillo, tipo CHc M 8 x 10	1
9	933 011 390	▪ Vis HM 8 x 30	▪ Screw, model HM 8 x 30	▪ Schraube HM 8 x 30	▪ Tornillo, tipo HM 8 x 30	2
13	963 040 019	▪ Rondelle MN 8	▪ Washer, model MN 8	▪ Scheibe MN 8	▪ Arandela, tipo MN 8	2
14	953 010 019	▪ Ecrou HM 8	▪ Nut, model HM 8	▪ Mutter, model HM 8	▪ Tuerca, tipo HM 8	2
19	88 664	▪ Rondelle W8	▪ Washer, model W8	▪ Scheibe W8	▪ Arandela, tipo W8	2
10	-	Equipement d'air	Air supply	Luftausrüstung	Equipo de aire	1
11	151 790 160	▪ Equipement d'air (air moteur) (voir Doc. 573.403.050)	▪ Air supply (motor air) (refer to Doc. 573.403.050)	▪ Luftausrüstung (Luftmotor) (siehe Dok. 573.403.050)	▪ Equipo de aire (aire motor) (consultar Doc. 573.403.050)	1
12	151 740 300	▪ Kit air de pulvérisation (air pistolet) (voir Doc. 573.035.050)	▪ Spraying air kit (spray gun air) (refer to Doc. 573.035.050)	▪ Zerstäuberluft-Kit (Pistolenluft) (siehe Dok. 573.035.050)	▪ Kit aire de pulverización (aire pistola) (consultar Doc. 573.035.050)	
16	050 102 401	Raccord M 1/2 BSP - M 3/4 BSP	Fitting, double male, 1/2 BSP - 3/4 BSP	Doppelnippel AG 1/2 BSP - 3/4 BSP	Racor M 1/2 BSP - M 3/4 BSP	1
18	050 102 437	Raccord inox M 1/2 BSP - M 26 x 125 (entrée produit)	Fitting, stainless steel, double male, 1/2 BSP - 26 x 125 (fluid inlet)	Doppelnippel, Edelstahl AG 1/2 BSP - M 26 x 1,25 (Materialeingang)	Racor, inox M 1/2 BSP - M 26 x 125 (entrada producto)	1

Ind	#	Désignation	Description	Bezeichnung	Denominación	Qté
20	149 596 150	Canne d'aspiration Ø 25 (Lg. 600 mm)	Suction rod Ø 25 (Length 600 mm)	Saugschlauch Ø 25 (Länge 600 mm)	Caña de aspiración Ø 25 (Longitud 600 mm)	1
21	149 596 152	▪ Crépine Ø 25	▪ Strainer Ø 25	▪ Siebkorb Ø 25	▪ Piña Ø 25	1
26	552 473	Mamelon réduit MM 3/8" - 1/2"	Nipple, double male, 3/8" - 1/2"	Rohrnippel AG/AG 3/8" - 1/2"	Pivote de centrado, MM 3/8" - 1/2"	1
27	552 428	Coude BP FF 1/2"	Elbow, BP FF 1/2"	Winkelnippel BP IG 1/2"	Codo, BP HH 1/2"	1

POMPE MURALE, modèle 20C100 T (turbo) sans filtre, ni canne	WALL MOUNTED PUMP, model 20C100 T (turbo) without filter or rod	#
WANDANLAGE, Modell 20C100 T (Turbo) ohne Filter, ohne Entleerungsschlauch	BOMBA MURAL, tipo 20C100 T (turbo) sin filtro y caña	151.782.100

Ind	#	Désignation	Description	Bezeichnung	Denominación	Qté
-	151 782 000	Pompe 20C100 T nue	Bare pump, model 20C100 T	Pumpe 20C100 T nackt	Bomba sola, tipo 20C100 T	1
*1	146 276 000	▪ Moteur 1000-4T (turbo) (voir Doc. 573.045.050)	▪ Air motor, model 1000-4T (turbo) (refer to Doc. 573.045.050)	▪ Motor 1000-4T (Turbo) (siehe Dok. 573.045.050)	▪ Motor, tipo 1000-4T (turbo) (consultar Doc. 573.045.050)	1
*2	144 960 000	▪ Hydraulique C100 (voir Doc. 573.080.050)	▪ Fluid section, model C100 (refer to Doc. 573.080.050)	▪ Hydraulikteil C100 (siehe Dok. 573.080.050)	▪ Hidráulica, tipo C100 (consultar Doc. 573.080.050)	1
3	051 770 001	▪ Tirant	▪ Tie-rod, connecting	▪ Bolzen	▪ Tirante	4
4	953 010 021	▪ Ecrou HM 10	▪ Nut, HM 10	▪ Mutter HM 10	▪ Tuerca HM 10	4
5	963 040 021	▪ Rondelle MN 10	▪ Washer, MN 10	▪ Scheibe MN 10	▪ Arandela MN 10	4
-	050 311 902	▪ Ressort de protection	▪ Protective spring	▪ Feder	▪ Muelle de protección	1
*-	151 775 010	Ensemble fixation	Mounting assembly	Montageplatte kpl.	Conjunto de fijación	1
6	051 770 101	▪ Plaque d'interface	▪ Plate	▪ Befestigungsplatte	▪ Placa	1
7	933 011 279	▪ Vis H 8 x 20	▪ Screw, model H 8 x 20	▪ Schraube M 8 x 20	▪ Tornillo, tipo H 8 x 20	1
8	933 151 147	▪ Vis CHc M 8 x 10	▪ Screw, model SHC M 8 x 10	▪ Schraube CHc M 8 x 10	▪ Tornillo, tipo CHc M 8 x 10	1
9	933 011 390	▪ Vis HM 8 x 30	▪ Screw, model HM 8 x 30	▪ Schraube HM 8 x 30	▪ Tornillo, tipo HM 8 x 30	2
13	963 040 019	▪ Rondelle MN 8	▪ Washer, model MN 8	▪ Scheibe MN 8	▪ Arandela, tipo MN 8	2
14	953 010 019	▪ Ecrou HM 8	▪ Nut, model HM 8	▪ Mutter, model HM 8	▪ Tuerca, tipo HM 8	2
19	88 664	▪ Rondelle W8	▪ Washer, model W8	▪ Scheibe W8	▪ Arandela, tipo W8	2
11	151 796 150	Equipement d'air (air moteur) (voir Doc. 573.403.050)	Air supply (motor air) (refer to Doc. 573.403.050)	Luftausrüstung (Motorluft) (siehe Dok. 573.403.050)	Air supply (aire motor) (consultar Doc. 573.403.050)	1
18	050 102 437	Raccord inox M 1/2 BSP - M 26 x 125 (entrée produit)	Fitting, stainless steel, double male, 1/2 BSP - 26 x 125 (fluid inlet)	Doppelnippel AG 1/2 BSP - M 26 x 1,25 (Materialeingang)	Racor, inox M 1/2 BSP - M 26 x 125 (entrada producto)	1

Nota : Dans le cas d'une pompe nue pour fixation murale, commander la pompe nue, la plaque d'interface (ind. 6) et le support réf. 044.910.121 (ind. 1 - Doc. 573.403.050).

Nota : For a bare pump with wall bracket, order bare pump, plate (ind. 6) and bracket - P.N°. 044.910.121 (ind. 1 - Doc. 573.403.050).

Anmerkung: Für eine Pumpe mit Wandhalterung, bestellen Sie die nackte Pumpe, die Verbindungsplatte (Pos. 6) und die Halterung, Bestell-Nr. 044.910.121 (siehe Pos. 1 - Dok. 573.403.050).

Nota : En caso de una bomba sola con fijación mural, encargue Vd. la bomba sola, la placa (índ. 6) y el soporte con la referencia 044.910.121 (índ. 1 - Doc. 573.403.050).

POMPE MURALE, modèle 20C100 avec filtre et canne d'aspiration	WALL MOUNTED PUMP, model 20C100 with filter and suction rod	#
WANDANLAGE, Modell 20C100 mit Filter und Saugschlauch	BOMBA MURAL, tipo 20C100 con filtro y caña de aspiración	151.780.200

Ind	#	Désignation	Description	Bezeichnung	Denominación	Qté
-	-	Pompe murale sans filtre avec canne	Wall mounted pump without filter, with suction rod	Wandpumpe ohne Filter, mit Saugschlauch	Bomba mural sin filtro, con caña de aspiración	1
22	155 580 300	Filtre AIRMIX® inox 3/8 (voir Doc. 573.299.050)	AIRMIX® filter 3/8, stainless steel (refer to Doc. 573.299.050)	AIRMIX® Filter 3/8, Edelstahl (siehe Doc. 573.299.050)	Filtro AIRMIX® inox 3/8 (consultar Doc. 573.299.050)	1
23	055 580 301	Manchon inox MM 3/8 NPT	Sleeve, stainless steel MM 3/8 NPT	Langnippel, Edelstahl AG 3/8 NPT	Manguito inox MM 3/8 NPT	1
25	049 596 000	Canne de purge inox Ø 16	Drain rod, stainless steel Ø 16	Entleerungsschlauch, Edelstahl Ø 16	Caña de purga inox Ø 16	1

POMPE 20C100 SUR CHARIOT	CART MOUNTED PUMP, model 20C100	#
PUMPE 20C100 FAHRBAR	BOMBA 20C100 SOBRE CARRETILLA	151.780.400

Ind	#	Désignation	Description	Bezeichnung	Denominación	Qté
-	-	Pompe murale avec filtre	Wall mounted pump with filter	Wandpumpe mit Filter	Bomba mural con filtro	1
-	051 221 000	Chariot (2 bras)	Cart (2 arms)	Fahrgestell (2 Arme)	Carretilla (2 brazos)	1
-	056 100 199	Panneau de fixation	Wall bracket unit	Wandplatte	Soporte de fijación	1

POMPE MURALE, modèle 20C100 T (turbo) avec filtre et canne d'aspiration	WALL MOUNTED PUMP, model 20C100 T (turbo) with filter and suction rod	# 151.782.200
WANDANLAGE, Modell 20C100 T (Turbo) mit Filter und Saugschlauch	BOMBA MURAL, tipo 20C100 T (turbo) con filtro y caña de aspiración	

Ind	#	Désignation	Description	Bezeichnung	Denominación	Qté
-	-	Pompe murale sans filtre	Wall mounted pump without filter	Wandpumpe ohne Filter	Bomba mural sin filtro	1
20	149 596 150	Canne d'aspiration Ø 25 (Lg. 600 mm)	Suction rod Ø 25 (Length 600 mm)	Saugschlauch Ø 25 (Länge 600 mm)	Caña de aspiración Ø 25 (Longitud 600 mm)	1
22	155 580 300	Filtre AIRMIX® inox 3/8 (voir Doc. 573.299.050)	AIRMIX® filter 3/8, stainless steel (refer to Doc. 573.299.050)	AIRMIX® Filter 3/8, Edelstahl (siehe Doc. 573.299.050)	Filtro AIRMIX® inox 3/8 (consultar Doc. 573.299.050)	1
23	055 580 301	Manchon inox MM 3/8 NPT	Sleeve, stainless steel MM 3/8 NPT	Langnippel, Edelstahl AG 3/8 NPT	Manguito inox MM 3/8 NPT	1
25	049 596 000	Canne de purge inox	Drain rod, stainless steel	Entleerungsschlauch, Edelstahl	Caña de purga inox	1

OPTIONS - ON REQUEST - OPTIONEN - OPCIONES

Ind	#	Désignation	Description	Bezeichnung	Denominación	Qté
20	149 596 150	Canne d'aspiration Ø 25 (Lg. 600 mm)	Suction rod Ø 25 (Length 600 mm)	Saugschlauch Ø 25 (Länge 600 mm)	Caña de aspiración Ø 25 (Longitud 600 mm)	1
21	149 596 152	▪ Crépine Ø 25	▪ Strainer Ø 25	▪ Siebkörbe Ø 25	▪ Piña Ø 25	1
20	149 596 160	Canne d'aspiration Ø 25 pour fût 200L (Lg. 1m)	Suction rod Ø 25 for drum 200L (Length : 1m)	Saugschlauch Ø 25 für 200L Fass (Länge: 1m)	Caña de aspiración Ø 25 para bidón de 200L (Longitud : 1m)	1
21	149 596 152	▪ Crépine Ø 25	▪ Strainer Ø 25	▪ Siebkorb Ø 25	▪ Piña Ø 25	1
-	151 740 200	Kit air de pulvérisation (voir Doc. 573.035.050)	Atomizing air kit (refer to Doc.573.035.050)	Zerstäuberluft-Kit (siehe Dok. 573.035.050)	Kit aire de pulverización (consultar Doc. 573.035.050)	1
-	151 740 300	Kit air de pulvérisation (voir Doc. 573.035.050)	Atomizing air kit (refer to Doc.573.035.050)	Zerstäuberluft-Kit (siehe Dok. 573.035.050)	Kit aire de pulverización (consultar Doc. 573.035.050)	1

ACCESSOIRES - ACCESSORIES - ZUBEHÖR - ACCESORIOS

Ind	#	Désignation	Description	Bezeichnung	Denominación	Qté
-	149 990 020	Flacon de lubrifiant T (125 ml)	T lubricant (125 ml / 4.4 oz)	Spülmittel T (125 ml)	Botella de lubricante T (125 ml)	1
-	044 950 008	Clé (pour cuve presse-garniture)	Wrench (for wetting cup)	Schlüssel für Spülmitteltasse	Llave (para prensaestopa)	1

* Pièces de maintenance préconisées.

* Preceding the index number denotes a suggested spare part.

* Bezeichnete Teile sind empfohlene Ersatzteile.

* Piezas de mantenimiento preventivas.

<p>Doc. 573.045.050 Date/Datum/Fecha : 07/03/18 Annule/Cancel/ Ersetzt/Anula : 20/05/14</p>	<p>Modif. / Änderung : # 044 630 400 → NC (ind. 9a / Pos. 9a) + # 144 630 720 (ind. 9b / Pos. 9b)</p>	<p>Pièces de rechange Spare parts list Ersatzteilliste Piezas de repuesto</p>
---	--	--

MOTEUR A AIR, modèle 1000-4 & 1000-4T	AIR MOTOR, model 1000-4 & 1000-4T
LUFTMOTOR, Modell 1000-4 & 1000-4T	MOTOR DE AIRE, tipo 1000-4 & 1000-4T

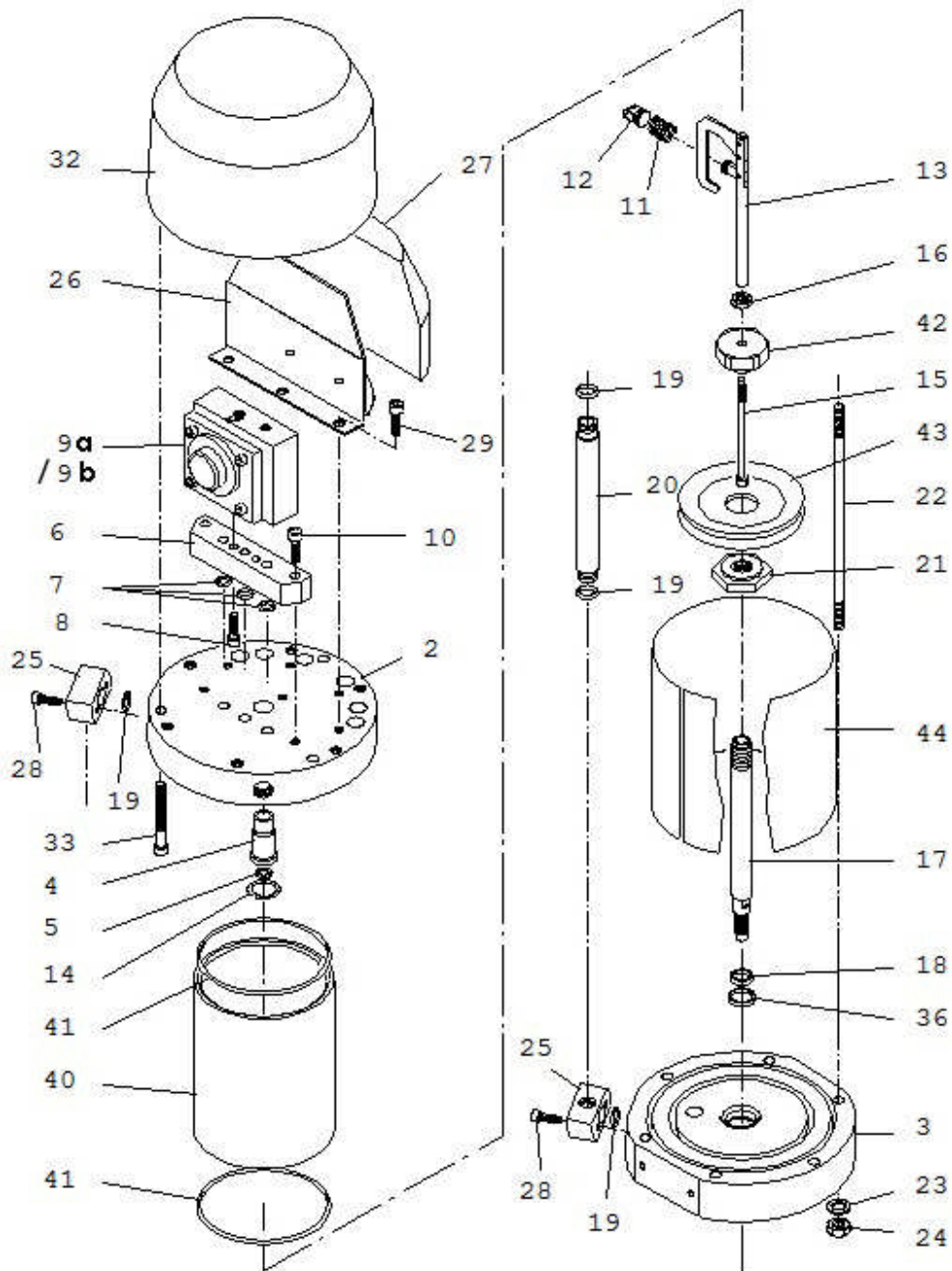

MOTEUR A AIR, modèle 1000-4	AIR MOTOR, model 1000-4	# 146.275.000
LUFTMOTOR, Modell 1000-4	MOTOR DE AIRE, tipo 1000-4	

Pièces spécifiques - Specific parts - Spezifische Teile - Partes específicas

Moteur / Motor 1000-4

Ind	#	Désignation	Description	Bezeichnung	Denominación	Qté
2	046 270 901	Fond supérieur	Upper flange	Oberer Flansch	Fondo superior	1
6	046 230 005	Embase bloc inverseur	Base, reversing-block	Grundplatte, Umsteuerblock	Base bloque inversor	1
20	046 144 901	Tube d'alimentation	Tube, connecting	Versorgungsrohr	Tubo de alimentación	1
25	046 270 903	Collecteur	Collector	Verbindungsflansch	Colector	2
26	046 270 904	Support (silencieux)	Support (silencer)	Halterung (Schalldämpfer)	Soporte (silenciador)	1
27	046 270 905	Silencieux (mousse)	Silencer	Schalldämpfer (Schaumstoff)	Silenciador	1
28	933 151 443	Vis CHc M 6 x 35	Screw, CHc M 6 x 35	Schraube CHc AG 6 x35	Tornillo, CHc M 6 x 35	4
29	933 151 122	Vis CHc M 6 x 8	Screw, CHc M 6 x 8	Schraube CHc AG 6 x 8	Tornillo, CHc M 6 x 8	3

Pièces communes - Common parts - Gleiche Teile - Partes comunes

Moteur / Motor 1000-4 & 1000-4T (turbo)

Ind	#	Désignation	Description	Bezeichnung	Denominación	Qté
3	146 270 902	Fond inférieur	Lower flange	Unterer Flansch	Fondo inferior	1
4	044 570 106	Bague de guidage	Guide ring	Führungsring	Anillo guía	1
5	144 579 923	Bague R 8 bis (pochette de 10)	Ring, R 8 bis (package of 10)	O-Ring R 8 bis (10er Pack)	Anillo R 8 bis (bolsa de 10)	1
7	109 420 257	Bague O Ring (pochette de 10)	O Ring (package of 10)	O-Ring (10er Pack)	Anillo O Ring (bolsa de 10)	3
8	933 151 277	Vis CHc M 6 x 20	Screw, CHc M 6 x 20	Schraube CHc M 6 x 20	Tornillo CHc M 6 x 20	2
9a	NC / NS	Bloc inverseur (voir Doc. 573.087.040)	Reversing block (refer to Doc. 573.087.040)	Umsteuerblock (siehe Dok. 573.087.040)	Bloque inversor (consultar Doc. 573.087.040)	1
*9b	144 630 720	Bloc inverseur droit avec deux roulements (voir Doc. 573.087.040)	Right reversing-block with two bearings (refer to Doc. 573.087.040)	Rechter Umsteuerblock mit zwei Lagerbuchsen (siehe Dok. 573.087.040)	Bloque inversor derecho con dos rodamientos (consultar Doc. 573.087.040)	1
10	930 151 446	Vis CHc M 8 x 35	Screw, CHc M 8 x 35	Schraube CHc M 8 x 35	Tornillo, CHc M 8 x 35	2
11	050 311 232	Ressort	Spring	Feder	Muelle	1
12	044 570 131	Chape femelle	Linkage, female	Verbindungsflansch	Unión hembra	1
13	044 570 900	Fourchette de commande équipée	Control fork assembly	Steuergabel; komplett	Horquilla de mando equipada	1
14	902 202 002	Anneau truarc	Retaining ring	Sicherungsring	Anillo truarc	1
15	046 180 003	Tige de pilotage	Rod, driving	Steuerstange	Eje de mando	1
16	046 144 907	Ecrou	Nut	Mutter	Tuerca	1
17	046 180 007	Tige de piston	Rod, piston	Kolbenstange	Eje de pistón	1

Ind	#	Désignation	Description	Bezeichnung	Denominación	Qté
18	046 180 010	Bague de frottement	Seal, ring	Dichtring	Anillo de deslizamiento	1
19	129 400 902	Joint (pochette de 10)	Seal (package of 10)	O-Ring (10er Pack)	Junta (bolsa de 10)	4
21	000 323 716	Contre écrou inférieur	Lower locknut	Untere Kontermutter	Contratuerca inferior	1
22	044 710 007	Tirant	Tie-rod	Bolzen	Tirante	6
23	963 040 019	Rondelle MN 8	Washer, MN 8	Scheibe MN 8	Arandela MN 8	6
24	953 010 019	Ecrou HM 8	Nut, HM 8	Mutter HM 8	Tuerca HM 8	6
32	046 180 006	Capot moteur	Cover, air motor	Motorhaube	Campana del motor	1
33	933 151 497	Vis CHc M 6 x 40	Screw, CHc M 6 x 40	Schraube CHc M 6 x 40	Tornillo CHc M 6 x 40	3
36	909 420 291	Joint	Seal	O-Ring	Junta	1
*40	046 275 001	Cylindre	Cylinder	Zylinder	Cilindro	1
41	100 940 470	Joint de cylindre (x 10)	Seal, cylinder (x 10)	O-Ring, Zylinders (10 St.)	Junta de cilindro (x 10)	2
42	046 144 908	Ecrou de piston	Nut, piston	Kolbenmutter	Tuerca de pistón	1
43	000 323 717	Piston	Piston	Kolben	Pistón	1
44	046 275 002	Virole	Muffler	Muffe	Virola	1
-	901 180 024	Cable de mise à la terre (Lg. 5 m)	Ground (Length 5 m / 16 ft)	Erdungskabel (Länge 5m)	Cable de puesta a tierra (5 m de largo)	1
-	963 300 016	Rondelle	Washer	Scheibe	Arandela	1
-	934 011 196	Vis Hc 6 x 16	Screw Hc 6 x 16	Schraube Hc 6 x 16	Tornillo Hc 6 x 16	1

Ind	#	Désignation	Description	Bezeichnung	Denominación	Qté
*	146 270 991	Pochette de joints moteur (ind. 5, 7(x3), 11, 18, 19(x5), 36, 41(x2) + pochette de joints inverseur)	Package of seals of the air motor (ind. 5, 7(x3), 11, 18, 19(x5), 36, 41(x2) + package of seals of the reversing block)	Dichtungssatz für Motor (Pos. 5, 7(x3), 11, 18, 19(x5), 36, 41(x2) + Dichtungssatz für Umsteuerblock)	Bolsa de juntas motor (ind. 5, 7(x3), 11, 18, 19(x5), 36, 41(x2) + bolsa de juntas del inversor)	1
*	146 270 995	Pochette de maintenance (ind. 4, 43 + pochette de joints moteur + ind. 2, 4, 7, 8, 13 de l'inverseur)	Servicing kit (ind. 4, 43 + package of seals of the air motor + ind. 2, 4, 7, 8, 13 of the reversing block)	Servicekit (Pos. 4, 43 + Dichtungssatz für Motor + 2, 4, 7, 8, 13 für Umsteuerblock)	Bolsa de mantenimiento (ind. 4, 43 + bolsa de juntas motor + ind. 2, 4, 7, 8, 13 del inversor)	1

* Pièces de maintenance préconisées.

* Preceding the index number denotes a suggested spare part.

* Bezeichnete Teile sind empfohlene Ersatzteile.

* Piezas de mantenimiento preventivas.

N C : Non commercialisé.

N S : Denotes parts are not serviceable.

N S : bezeichnete Teile gibt es nicht einzeln, sondern nur komplett.

N S : no suministrado.

Nota : Les pompes dont le numéro de série est > à 17 AJ 1291 sont équipées du bloc inverseur # 144.630.720. Ne monter l'ind. 2 (bague de guidage du bloc inverseur) que si votre bloc comporte un R.

Nota : The pumps with serial number is > to 17 AJ 1291 are fitted with the reversing-block # 144.630.720. Install ind. 2 (guide ring of the reversing-block) only if your reversing-block has R.

Hinweis: Die Pumpen mit der Fertigungsnummer > bis 17 AJ 1291 sind mit dem Umsteuerblock # 144.630.720 bestückt. Die Pos. 2 (Führungsbuchse des Umsteuerblocks) nur am Umsteuerblock mit R Markierung montieren.

Nota : Las bombas cuyo número de serie es > a 17 AJ 1291 tienen el bloque inversor # 144.630.720. Montar el ind. 2 (anillo guía del bloque inversor) sólo si su bloque tiene un R.

MOTEUR A AIR, modèle 1000-4T (turbo)	AIR MOTOR, model 1000-4T (turbo)	# 146.276.000
LUFTMOTOR, Modell 1000-4T (turbo)	MOTOR DE AIRE, tipo 1000-4T turbo)	

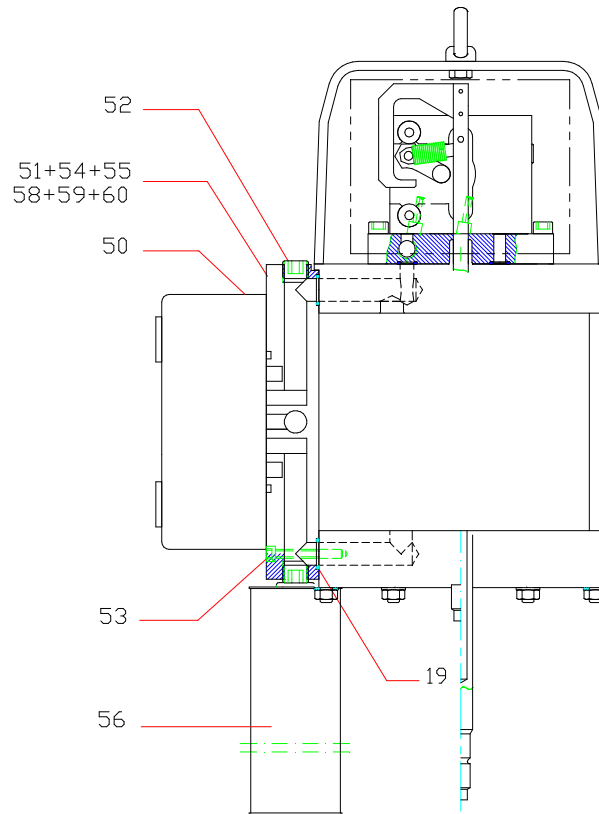

Ind	#	Désignation	Description	Bezeichnung	Denominación	Qté
		Pièces spécifiques au moteur 1000-4T	Specific parts to the air motor, model 1000-4T	Spezielle Teile für Luftmotor 1000-4T	Partes específicas al motor, tipo 1000-4T	
2	046 271 001	Fond supérieur	Upper flange	Oberer Flansch	Fondo superior	1
6	046 271 002	Embase bloc inverseur	Base, reversing block	Grundplatte, Umsteuerblock	Base, bloque inversor	1
50	903 050 511	Distributeur 5/2 - T3	Distributor, 5/2 - T3	Verteiler 5/2 - T3	Distribuidor, 5/2 - T3	1
51	046 271 004	Embase distributeur	Base, distributor	Grundplatte, Verteiler	Base distribuidor	1
52	906 333 105	Bouchon 3/4 BSP (pour embase)	Plug, 3/4 BSP (for base)	Stopfen 3/4 BSP (für Grundplatte)	Tapón 3/4 BSP (para base)	4
53	930 151 548	Vis CHc M 6 x 50	Screw, CHc M 6 x 50	Schraube CHc M 6 x 50	Tornillo CHc M 6 x 50	4
54	905 120 905	Raccord coudé M 1/4 BSP - T 4x6	Elbow fitting, M 1/4 BSP - T 4x6	Winkelniessel AG 1/4 BSP - T 4 x 6	Racor acodado M 1/4 BSP - T 4x6	5
55	050 371 001	Tuyau 4x6 (lg. 25 m)	Hose, 4x6 (length : 25 m / 984")	Schlauch 4x6 (Länge 25 m)	Tubería 4x6 (25 m de largo)	1
56	046 250 015	Silencieux	Silencer	Schalldämpfer	Silenciador	1
58	050 102 215	Raccord MM 3/4 BSP	Fitting, double male, 3/4 BSP	Nippel AG 3/4 BSP	Racor, MM 3/4 BSP	1
59	904 123 006	Coude 3/4	Elbow, 3/4	Winkel 3/4	Codo 3/4	1
60	050 102 634	Raccord M 3/4 BSP - 3/4 NPS (alimentation en air)	Fitting, M 3/4 BSP - 3/4 NPS (air supply)	Nippel AG 3/4 BSP - 3/4 NPS (Luftversorgung)	Racor M 3/4 BSP - 3/4 NPS (alimentación en aire)	1

Doc. 573.087.040 Date/Datum/Fecha : 11/05/17 Annule/Cancela/ Ersetzt/Anula : 03/06/14	Modif. / Änderung : Mise à jour / Update / Aktualisierung / Actualización + 144.630.720	Pièces de rechange Spare parts list Ersatzteilliste Piezas de repuesto
---	---	---

BLOC INVERSEUR	REVERSING-BLOCK	#
UMSTUEBERBLOCK	BLOQUE INVERSOR	NC / NS

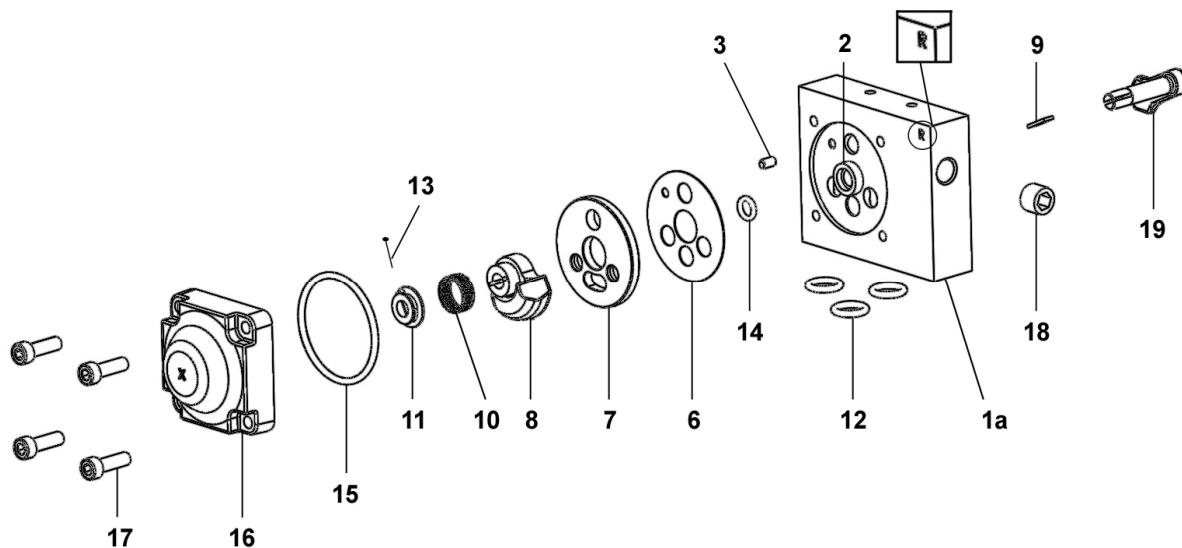

BLOC INVERSEUR DROIT AVEC DEUX ROULEMENTS	RIGHT REVERSING-BLOCK WITH TWO BEARINGS	#
RECHTER UMSTUEBERBLOCK MIT ZWEI LAGERBUCHSEN	BLOQUE INVERSOR DERECHO CON DOS RODAMIENTOS	144.630.720

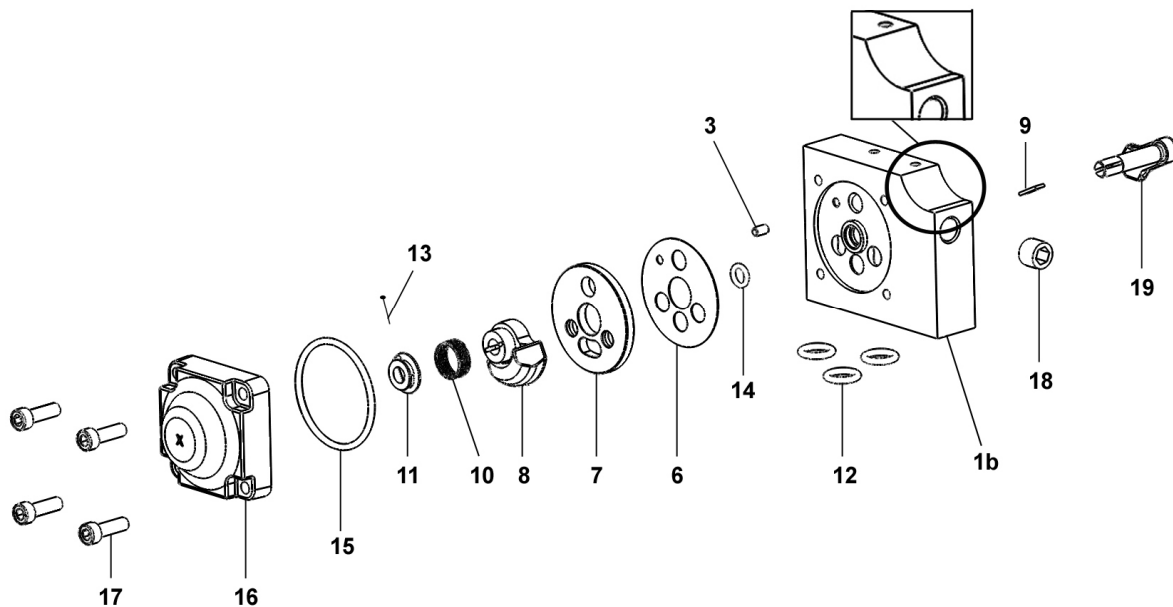

BLOC INVERSEUR	REVERSING-BLOCK	#
UMSTUEERBLOCK	BLOQUE INVERSOR	NC / NS

BLOC INVERSEUR DROIT AVEC DEUX ROULEMENTS	RIGHT REVERSING-BLOCK WITH TWO BEARINGS	#
RECHTER UMSTUEERBLOCK MIT ZWEI LAGERBUCHSEN	BLOQUE INVERSOR DERECHO CON DOS RODAMIENTOS	144.630.720

Pièces communes - Common parts - Gleiche Teile - Partes comunes

Ind	#	Désignation	Description	Bezeichnung	Denominación	Qté
*6	144 579 912	Joint de glace fixe (x 10)	Gasket seal (x 10)	Flachdichtung (10 x)	Junta de espejo fijo (x 10)	1
*7	046 170 508	Glace fixe	Base, fixed	Ventilplatte	Espejo fijo	1
*8	044 570 324	Glace mobile	Base, mobile	Ventilschieber	Espejo móvil	1
9	044 570 325	Clavette	Pin	Paßfeder (Keil)	Pasador	1
10	921 140 102	Ressort	Spring	Feder	Muelle	1
11	044 571 006	Butée de ressort	Stop, spring	Federführung	Tope de muelle	1
*12	144 579 922	Bague R 10 (x 10)	Ring, model R 10 (x 10)	O Ring R 10 (x 10)	Anillo, tipo R 10 (x 10)	3
*13	144 579 911	Goupille fendue (pochette de 10 goupilles + 1 butée ind. 11)	Pin (package of 10 pins + 1 stop ind. 11)	Splint (Satz à 10 Stück + 1 Führung Pos. 11)	Pasador (bolsa de 10 pasadores + 1 tope ind. 11)	1
*14	144 579 910	Bague R 6a (x 10)	Ring, model R 6a (x 10)	O Ring, R 6a (10 x)	Anillo, tipo R 6a (x 10)	1
*15	N C / N S	Joint de couvercle	Seal, cover	Deckeldichtung	Junta de tapa	1
16	144 630 415	Couvercle	Cover	Deckel	Tapa	1
17	933 151 277	Vis CHc M 6x20	Screw, model CHc M 6x20	Schraube, CHc M 6x20	Tornillo, tipo CHc M 6x20	4
18	906 333 102	Bouchon 1/4 BSP	Plug, model 1/4 BSP	Blindstopfen, 1/4 BSP	Tapón, tipo 1/4 BSP	1
19	046 170 510	Levier	Lever, control	Umsteuerhebel	Leva	1

Ind	#	Désignation	Description	Bezeichnung	Denominación	Qté
*	146 270 950	Pochette de joints (ind. 6, 12(x3), 14, 15)	Package of seals (ind. 6, 12(x3), 14, 15)	Dichtungssatz (bestehend aus Pos. 6, 12(x3), 14, 15)	Bolsa de juntas (ind. 6, 12(x3), 14, 15)	1
*	144 630 425	Pochette de maintenance glaces (ind. 7, 8)	Servicing kit - bases (ind. 7, 8)	Servicekit - Ventil (Pos. 7, 8)	Bolsa de mantenimiento - espejos (ind. 7, 8)	1

Pièces spécifiques - Specific parts - Spezifische Teile - Partes específicas

Pour / for / für / para # NC / NS

Ind	#	Désignation	Description	Bezeichnung	Denominación	Qté
*	144 630 410	Corps équipé	Block assembly, reversing	Umsteuerblock komplett	Cuerpo equipado	1
1a	N C / N S	▪ Corps	▪ Body	▪ Körper	▪ Cuerpo	1
2	N C / N S	▪ Bague de guidage	▪ Guide ring	▪ Führungsbuchse	▪ Anillo guía	1
3	N C / N S	▪ Goupille Ø 4 x 8	▪ Pin Ø 4 x 8	▪ Splint Ø4 x 8	▪ Pasador Ø 4 x 8	1
-	N C / N S	▪ Butée (collée sur corps ind.1a)	▪ Stop (glued on part ind. 1a)	▪ Anschlag (auf Körper geklebt ind.1a)	▪ Tope (pegado en cuerpo ind. 1a)	2
-	N C / N S	▪ Roulement à bille	▪ Ball bearing	▪ Kugellager	▪ Rodamiento de bolas	1

Pour / for / für / para # 144.630.720

Ind	#	Désignation	Description	Bezeichnung	Denominación	Qté
*	144 630 715	Corps équipé	Block assembly, reversing	Umsteuerblock komplett	Cuerpo equipado	1
1b	N C / N S	▪ Corps	▪ Body	▪ Körper	▪ Cuerpo	1
3	N C / N S	▪ Goupille Ø 4 x 8	▪ Pin Ø 4 x 8	▪ Splint Ø4 x 8	▪ Pasador Ø 4 x 8	1
-	N C / N S	▪ Butée (collée sur corps ind.1b)	▪ Stop (glued on part ind. 1b)	▪ Anschlag (auf Körper geklebt ind.1b)	▪ Tope (pegado en cuerpo ind. 1b)	2
-	N C / N S	▪ Roulement à bille	▪ Ball bearing	▪ Kugellager	▪ Rodamiento de bolas	2

* Pièces de maintenance préconisées.

* Preceding the index number denotes a suggested spare part.

* Bezeichnete Teile sind empfohlene Ersatzteile.

* Piezas de mantenimiento preventivas.

N C : Non commercialisé.

N S : Denotes parts are not serviceable.

N S : Bezeichnete Teile gibt es nicht einzeln, sondern nur komplett .

N S : no suministrado.

Nota : Ne monter l'ind. 2 (bague de guidage du bloc inverseur) que si votre bloc inverseur comporte un R.

Nota : Install ind. 2 (guide ring of the reversing-block) only if your reversing-block has R.

Hinweis: Die Pos. 2 (Führungsbuchse des Umsteuerblocks) nur am Umsteuerblock mit R Markierung montieren.

Nota : Montar el ind. 2 (anillo guía del bloque inversor) sólo si su bloque inversor tiene un R.

Doc. 573.080.050 Date/Datum/Fecha : 11/06/18 Annule/Cancela/ Ersetzt/Anula : 11/10/11	Modif. / Änderung : Mise à jour / Update / Aktualisierung / Actualización	Pièces de rechange Spare parts list Ersatzteilliste Piezas de repuesto
---	--	---

HYDRAULIQUE, modèle C100 (garniture mobile avec joint GT)	FLUID SECTION, model C100 (mobile packing with GT seal)	#
HYDRAULIKTEIL, Modell C100 (mobile Packung mit GT-Dichtungsring)	HIDRÁULICA, tipo C100 (guarnición móvil con junta GT)	144.960.000

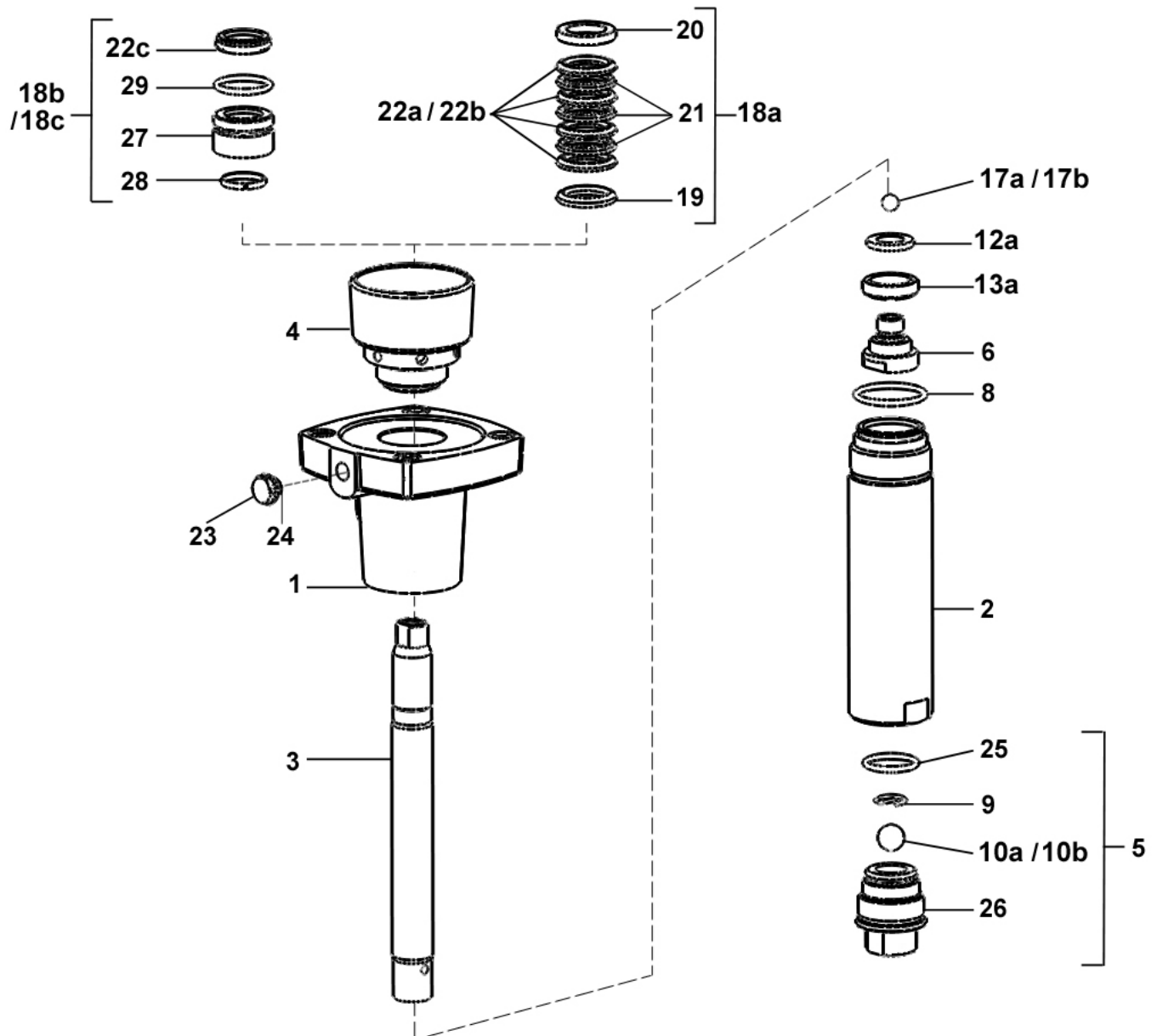

Hydraulique avec joint GT (à partir de la pompe N° série : 905 600)
Fluid section with GT seal (from pump serie N°: 905 600)
Hydraulikteil mit GT-Dichtungsring (ab Pumpe Serien-Nr. 905.600)
Hidráulica con junta GT (a partir de la bomba con el N° de serie : 905 600)

Ind	#	Désignation	Description	Bezeichnung	Denominación	Qté
1	044 960 001	Bride supérieure	Upper flange	oberer Flansch	Brida superior	1
*2	044 960 002	Cylindre	Cylinder	Materialzylinder	Cilindro	1
*3	044 960 003	Piston	Piston	Materialkolben	Pistón	1
4	044 950 004	Cuve presse-garniture	Wetting-cup	Spülmitteltasse	Cubeta prensa-guarnición	1
5	044 950 010	Clapet d'aspiration assemblé	Suction valve assembly	Ansaugventil, komplett	Válvula aspiración completa	1
9	044 550 029	▪ Jonc	▪ Rush	▪ Sicherungsring	▪ Anillo de retención bola	1
10a	907 414 242	▪ Bille Ø 16, inox 440C	▪ Ball Ø 16 (5/8"), stainless steel 440C	▪ Kugel, Ø 16, Edelstahl 440C	▪ Bola Ø 16 de inox 440C	1
25	050 040 318	▪ Joint torique	▪ O Ring	▪ O-Ring	▪ Junta tórica	1
26	NC / NS	▪ Corps de clapet	▪ Valve body	▪ Saugventil	▪ Cuerpo de válvula	1
*6	044 960 215	Clapet de refoulement	Exhaust valve	Druckventil	Válvula de expulsión	1
8	050 040 317	Joint torique	O Ring	O-Ring	Junta tórica	1
12a	044 960 204	Rondelle GT	Washer GT	Scheibe, GT	Arandela GT	1
13a	909 150 215	Joint GT inférieur (garniture mobile)	Seal GT lower (mobile packing)	GT Dichtung (mobile Packung)	Junta GT inferior (guarnición móvil)	1
17a	907 414 223	Bille Ø 9,52, inox 440C	Ball Ø 9,52 (3/8"), stainless steel 440C	Kugel, Ø 9,52, Edelstahl 440C	Bola Ø 9,52 de inox 440C	1
18a	-	Garniture supérieure	Upper packing	Obere Packung	Guarnición superior	1
19	044 960 011	▪ Bague male, inox	▪ Male ring, stainless steel	▪ Unterer Stützring, Edelstahl	▪ Anillo macho, inox	1
20	044 960 012	▪ Bague femelle, inox	▪ Female ring, stainless steel	▪ Oberer Stützring, Edelstahl	▪ Anillo hembra, inox	1
21	909 050 913	▪ Joint chevron, polyfluid	▪ Chevron seal, polyfluid	▪ Packungsring, Polyfluid	▪ Junta chevrón, polifluida	3
22a	109 050 818	▪ Joint chevron, PTFEG (pochette de 10)	▪ Chevron seal, PTFEG (pack of 10)	▪ Packungsring, PTFEG (10 St.)	▪ Junta chevrón, PTFEG (bolsa de 10)	4
23	144 950 012	Bouchon de vidange	Drain plug	Ablafschraube	Tapón de vaciado	1
24	109 020 401	▪ Joint plat (x 5)	▪ Flat seal (pack of 5)	▪ Flachdichtung (5 St.)	▪ Junta plana (bolsa de 5)	1

ACCESSOIRES - ACCESSORIES - ZUBEHÖR - ACCESORIOS

Ind. 31



Ind	#	Désignation	Description	Bezeichnung	Denominación	Qté
31	044 950 008	Clé pour cuve presse-garniture	Wrench for wetting-cup	Schlüssel für Spülmittel-tasse	Llave para prensaestopa	1
-	149 990 020	Flacon de lubrifiant T (125 ml)	T lubricant (125 ml / 4.4 oz)	Spülmittel T (125 ml)	Recipiente de lubricante T (125 ml)	1

POCHETTES - KITS - SÄTZE - BOLSAS

Ind	#	Désignation	Description	Bezeichnung	Denominación	Qté
*	144 960 091	Pochette de joints (ind. 8, 9, 10, 13, 17a, 21(x3), 22a(x4), 24, 25)	Package of seals (ind. 8, 9, 10, 13, 17a, 21(x3), 22a(x4), 24, 25)	Dichtungssatz (beinhaltet Pos. 8, 9, 10, 13, 17a, 21(x3), 22a(x4), 24, 25)	Bolsa de juntas (ind. 8, 9, 10, 13, 17a, 21(x3), 22a(x4), 24, 25)	1
*	144 960 096	Pochette de maintenance (ind. 5, 6, 12a + pochette de joints)	Servicing kit (ind. 5, 6, 12a + package of seals)	Servicekit (beinhaltet Pos. 5, 6, 12a und den Dichtungssatz)	Bolsa de mantenimiento (ind. 5, 6, 12a + bolsa de juntas)	1

* Pièces de maintenance préconisées.

* Preceding the index number denotes a suggested spare part.

* Bezeichnete Teile sind empfohlene Ersatzteile.

* Piezas de mantenimiento preventivas.

N C : Non commercialisé.

N S : Denotes parts are not serviceable.

N S : bezeichnete Teile gibt es nicht einzeln, sondern nur komplett.

N S : no suministrado.

OPTION - ON REQUEST - OPTIONEN - OPCIÓN

Ind	#	Désignation	Description	Bezeichnung	Denominación	Qté
10b	907 414 142	Bille Ø 16 inox 316 L	Ball Ø 16 stainless steel 316 L	Kugel (Edelstahl), Ø 16, 316 L	Bola Ø 16 de inox 316 L	1
17b	907 414 123	Bille Ø 9,52 inox 304 L	Ball Ø 9,52 stainless steel 304 L	Kugel (Edelstahl), Ø 9,52, 304 L	Bola Ø 9,52 de inox 304 L	1
18b	144 960 100	Cartouche supérieure avec joint GT	Upper packing with GT seal	Obere Packung, GT - Dichtung	Cartucho superior con junta GT	1
27	NC / NS	▪ Corps de cartouche	▪ Cartridge body	▪ Packungskörper	▪ Cuerpo de cartucho	1
28	NC / NS	▪ Segment	▪ Segment	▪ Ring	▪ Segmento	1
29	NC / NS	▪ Joint O-Ring noir	▪ O-Ring seal, black	▪ O-Ring, schwarz	▪ Junta tórica negra	1
22b	909 051 105	Joint chevron, PE	Chevron seal, PE	Packungsring, PE	Junta chevrón, PE	4

Pièces spécifiques - Specific parts - Spezifische Teile - Partes específicas

Pour garniture mobile avec joints chevrons / for mobile packing with chevron seals / für mobile Packung mit Packungsringen / para guarnición móvil con juntas de chevrón

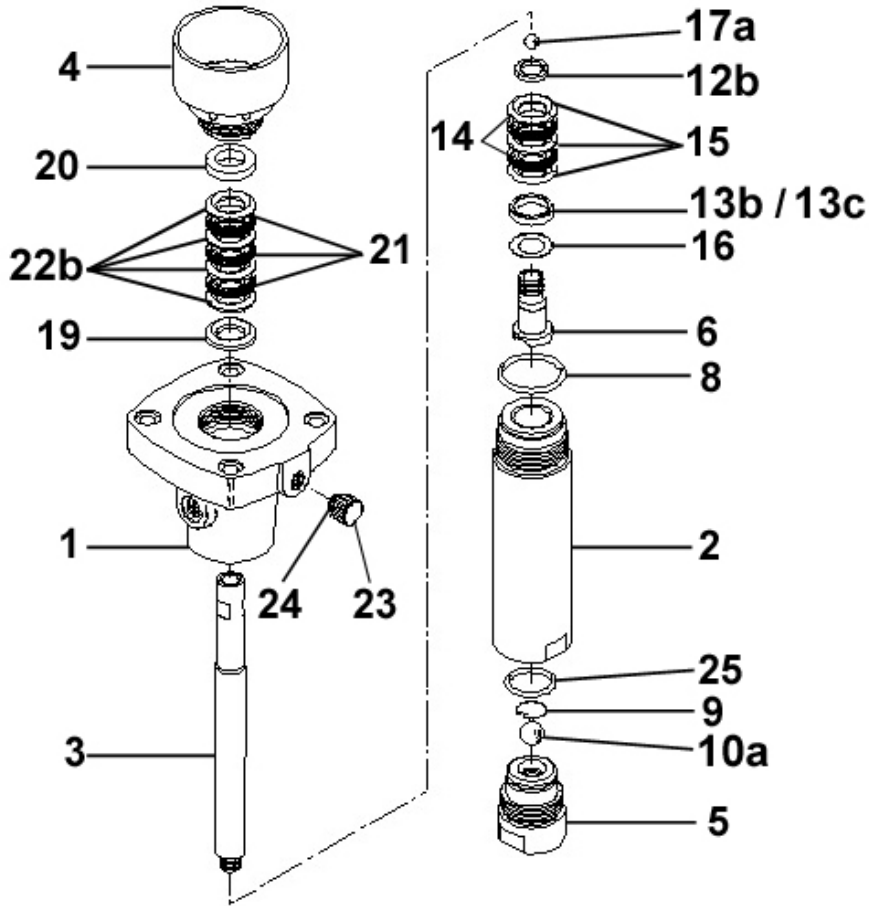

Ind	#	Désignation	Description	Bezeichnung	Denominación	Qté
6	044 960 010	Clapet de refoulement	Exhaust valve	Druckventil	Válvula de expulsión	1
12b	044 960 007	Rondelle mâle, inox	Male washer, stainless steel	Scheibe, außen, Edelstahl	Arandela macho, inox	1
13b	044 960 008	Rondelle femelle, inox	Female washer, stainless steel	Scheibe, innen, Edelstahl	Arandela hembra, inox	1
14	909 050 819	Joint chevron, PTFEG	Chevron seal, PTFEG	Packungsring, PTFEG	Junta chevrón, PTFEG	2
15	909 051 106	Joint chevron, PE	Chevron seal, PE	Packungsring, PE	Junta chevrón, PE	3
16	044 960 009	Rondelle de calage, inox (facultative)	Set ring, inox (optional)	Stützscheibe, Edelstahl (fakultativ)	Arandela inox (facultativa)	1

Ind	#	Désignation	Description	Bezeichnung	Denominación	Qté
*	144 960 090	Pochette de joints (ind. 8, 9, 10a, 14(x2), 15(x3), 16, 17a, 21(x3), 22b(x4), 24, 25)	Package of seals (ind. 8, 9, 10a, 14(x2), 15(x3), 16, 17a, 21(x3), 22b(x4), 24, 25)	Dichtungssatz (beinhaltet Pos. 8, 9, 10a, 14(x2), 15(x3), 16, 17a, 21(x3), 22b(x4), 24, 25)	Bolsa de juntas (ind. 8, 9, 10a, 14(x2), 15(x3), 16, 17a, 21(x3), 22b(x4), 24, 25)	1
*	144 960 095	Pochette de maintenance (ind. 5, 6 + pochette de joints)	Servicing kit (ind. 5, 6 + package of seals)	Servicekit (beinhaltet Pos. 5, 6 und den Dichtungssatz)	Bolsa de mantenimiento (ind. 5, 6 + bolsa de juntas)	1

Pour produit hydro / for hydro material / für Wassermaterialien / para producto hidro

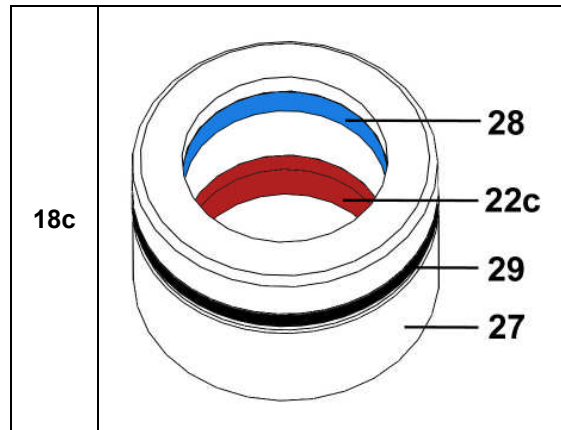

Ind	#	Désignation	Description	Bezeichnung	Denominación	Qté
13c	109 060 310	Joint de piston PU (pochette de 2)	Piston seal, Polyurethane (pack of 2)	Kolbendichtung, PU (2 St.)	Junta de pistón, Poliuretano (bolsa de 2)	1
18c	144 960 150	Cartouche supérieure avec joint PU	Upper packing with Polyurethane seal	Obere Packung, PU -Dichtung	Cartucho superior con junta de Poliuretano	1
22c	109 060 309	▪ Joint PU (pochette de 2)	▪ Seal, Polyurethane (pack of 2)	▪ PU-Dichtung (2 St.)	▪ Junta de Poliuretano (bolsa de 2)	1
27	NC / NS	▪ Corps de cartouche	▪ Cartridge body	▪ Packungskörper	▪ Cuerpo de cartucho	1
28	NC / NS	▪ Segment	▪ Segment	▪ Ring	▪ Segmento	1
29	NC / NS	▪ Joint O-Ring noir	▪ O-Ring seal, black	▪ O-Ring, schwarz	▪ Junta tórica negra	1

Ind	#	Désignation	Description	Bezeichnung	Denominación	Qté
*	144 960 159	Pochette de maintenance (ind. 8, 9, 10a, 13c, 17a, 18c, 25)	Service kit (ind. 8, 9, 10a, 13c, 17a, 18c, 25)	Servicekit (beinhaltet Pos. 8, 9, 10a, 13c, 17a, 18c, 25)	Bolsa de mantenimiento (ind. 8, 9, 10a, 13c, 17a, 18c, 25)	1

Doc. 573.403.050 Date/Datum/Fecha : 26/03/21 Annule/Cancel/ Ersetzt/Anula : 19/10/18	Modif. / Änderung : Mise à jour / Update / Aktualisierung / Actualización	Pièces de rechange Spare parts list Ersatzteilliste Piezas de repuesto
--	--	---

EQUIPEMENT D'AIR / AIR SUPPLY / LUFTAUSRÜSTUNG / EQUIPO DE AIRE
Avec 1 détendeur / with 1 air regulator / mit 1 Druckminderer / con 1 manorreductor,
Mod. 1/2"

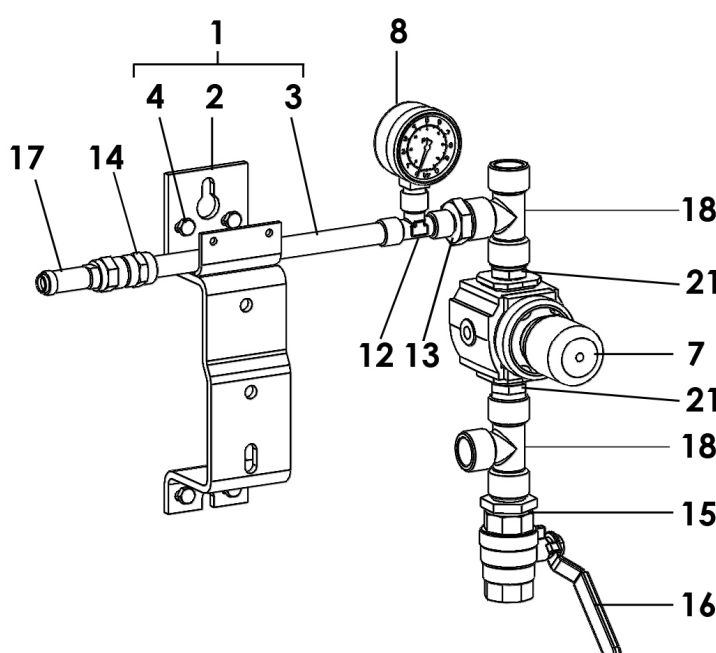
<p style="text-align: center;">Alimentation air Air supply Luftausrüstung Alimentación de aire</p> <p style="text-align: center; margin-top: 20px;"># NC / NS</p>	
---	---

Pièces communes - Common parts - Gleiche Teile - Partes comunes

Ind	#	Désignation	Description	Bezeichnung	Denominación	Qté
1	044 910 121	Support pompe équipé	Pump bracket assembly	Komplette Pumpenhalterung	Soporte de bomba equipado	1
2	044 910 122	▪ Support pompe	▪ Pump bracket	▪ Pumpenhalterung	▪ Soporte de bomba	1
3	051 751 011	▪ Support équipement d'air	▪ Air supply bracket	▪ Luftausrüstungs-halterung	▪ Soporte equipo de aire	1
4	144 910 129	▪ Pochette de 4 vis, 4 écrous, 4 rondelles	▪ Pack of 4 screws, 4 nuts, 4 washers	▪ Satz à 4 Schrauben, 4 Muttern, 4 Scheiben	▪ Bolsa de 4 tornillos, 4 tuercas, 4 arandelas	1
*7	NC / NS	Détendeur d'air 1/2 - 0 - 10 bar (volant phosphore)	Air regulator, model 1/2 - 0 - 10 bar / 0 - 145 psi (phosphorous knob)	Druckminderer, 1/2 - 0 - 10 bar (phosphor Stellglocke)	Manorreductor de aire, tipo 1/2 - 0 - 10 bar (pomo fósforo)	1
*8	910 011 402	Manomètre 0 - 10 bar	Gauge, 0 - 10 bar / 0 - 145 psi	Manometer, 0 - 10 bar	Manómetro, 0 - 10 bar	1
12	552 436	Té F 1/4"	Tee, F 1/4"	T-Stück , F 1/4"	Te, H 1/4"	1
13	552 475	Raccord M 1/4" - M 1/2"	Fitting, double male, 1/4" - 1/2"	Doppelnippel, AG 1/4" - AG 1/2"	Racor, M 1/4" - M 1/2"	1
14	552 486	Manchon 1/4"	Sleeve, 1/4"	Muffe 1/4"	Manguito 1/4"	1

Ind	#	Désignation	Description	Bezeichnung	Denominación	Qté
15	552 474	Raccord M 1/2" - M 3/4"	Fitting, double male, 1/2" - 3/4 "	Doppelnippel, AG 1/2 " - AG 3/4 "	Racor, M 1/2 "- M 3/4 "	1
16	903 090 208	Robinet F 3/4 BSP	Valve, F 3/4 BSP	Absperrhahn, F 3/4 BSP	Grifo, H 3/4 BSP	1
17	903 080 401	Soupape de décharge - tarage 6,5 bar	Discharge valve - setting 6.5 bar / 94 psi	Sicherheitsventil - eingestellt 6,5 bar	Válvula de seguridad - tarado 6,5 bar	1
18	552 438	Té F 1/2"	Tee, F 1/2"	T-Stück, F 1/2"	Te, H 1/2"	2
21	552 464	Mamelon MM 1/2"	Nipple, double male, 1/2"	Rohrnippel 1/2"	Pivote de centrado, MM 1/2"	2

➤ **Moteur / Motor, Mod. 1000-4 & 2000-4**

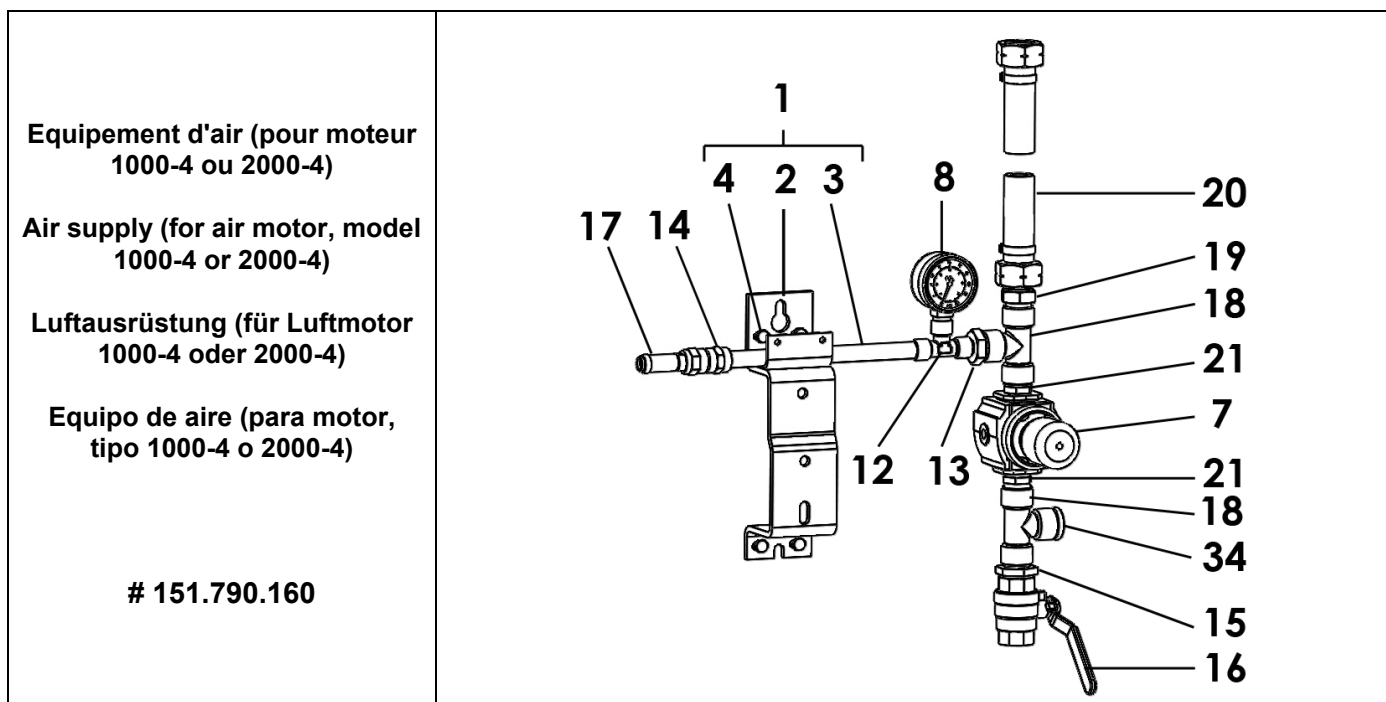

Pièces spécifiques - Specific parts - Spezifische Teile - Partes específicas

Ind	#	Désignation	Description	Bezeichnung	Denominación	Qté
19	050 102 401	Raccord M 1/2 BSP - M 3/4 NPS	Adaptor M 1/2 BSP - M 3/4 NPS	Nippel M 1/2 BSP - M 3/4 NPS	Racor, M 1/2 BSP - M 3/4 NPS	1
20	050 383 109	Tuyau Ø int. 16 (avec écrous 3/4 NPS)	Hose Ø 16 ID / 3/8 dia. (with nuts, 3/4 NPS)	Schlauch Ø 16 ID (mit Muttern 3/4 NPS)	Tubería Ø int. 16 (con tuercas 3/4 NPS)	1
34	905 210 305	Bouchon G 1/2"	Plug, G 1/2"	Blindstopfen, G 1/2"	Tapón, G 1/2"	1

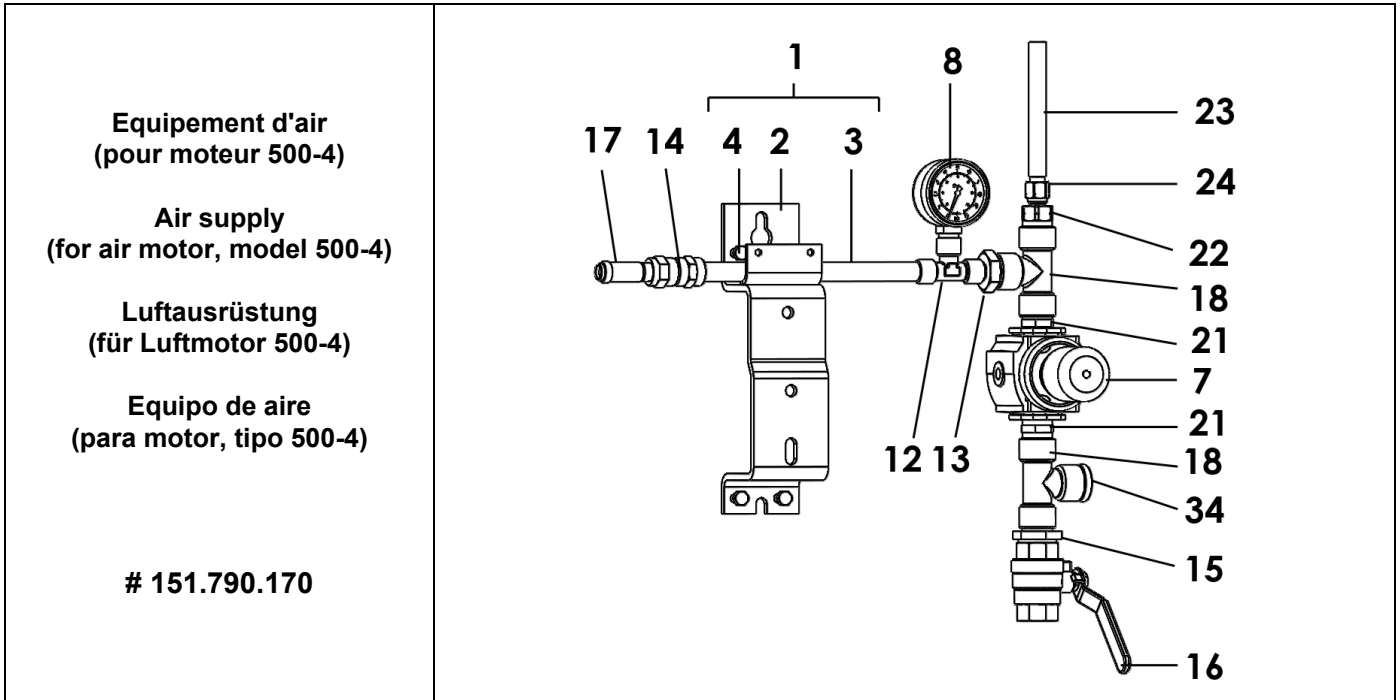

Pièces spécifiques - Specific parts - Spezifische Teile - Partes específicas

Ind	#	Désignation	Description	Bezeichnung	Denominación	Qté
22	050 102 633	Raccord M 1/2 BSP - M 1/4 NPS	Adaptor M 1/2 BSP - M 1/4 NPS	Nippel M 1/2 BSP - M 1/4 NPS	Racor M 1/2 BSP - M 1/4 NPS	1
23	050 372 226	Tuyau polyuréthane noir T 8x12	Hose (black), polyurethane T 8x12	Schwarzer Schlauch aus Polyurethan T 8x12	Tubería poliuretano (negra) T 8x12	1
24	050 231 702	Raccord droit avec écrou 1/4 NPS	Straight fitting with nut 1/4 NPS	Gerader Nippel mit Mutter 1/4 NPS	Racor recto con tuerca 1/4 NPS	1
34	905 210 305	Bouchon G 1/2"	Plug, G 1/2"	Blindstopfen, G 1/2	Tapón, G 1/2"	1

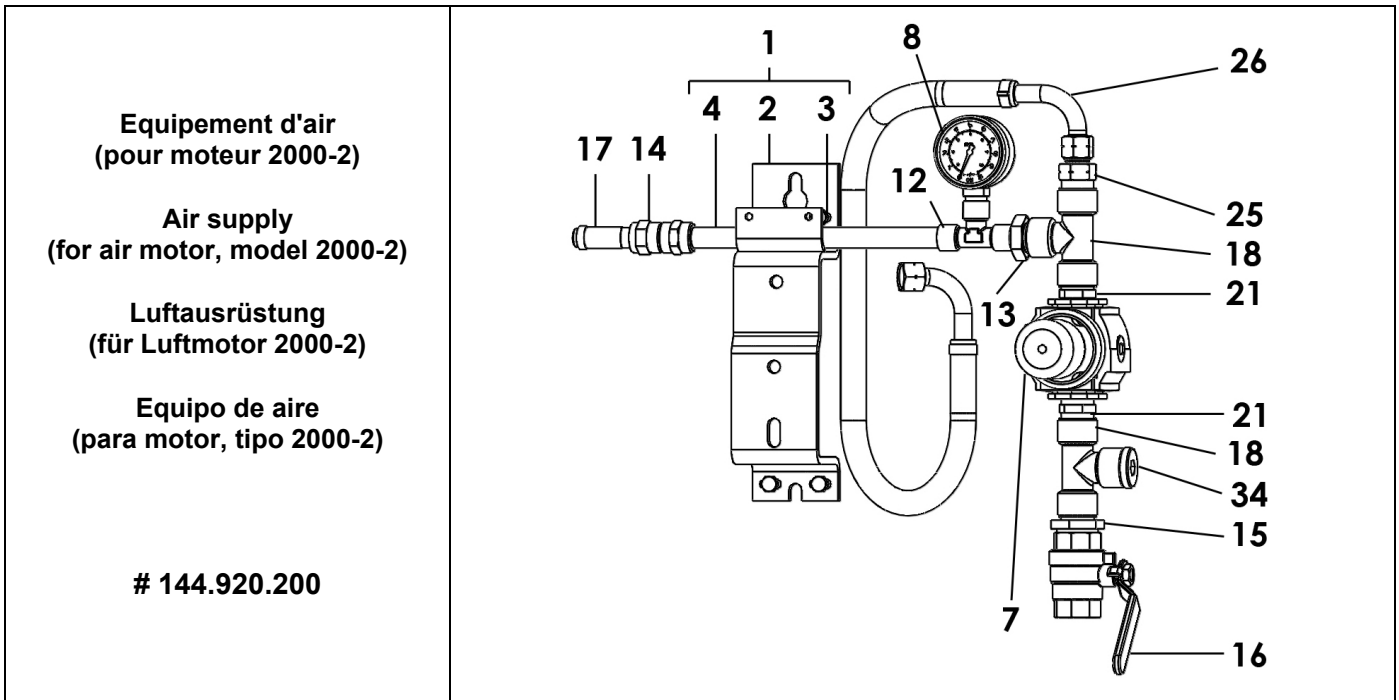

Pièces spécifiques - Specific parts - Spezifische Teile - Partes específicas

Ind	#	Désignation	Description	Bezeichnung	Denominación	Qté
25	050 102 629	Raccord M 1/2 BSP - M 3/8 NPS	Adaptor M 1/2 BSP - M 3/8 NPS	Nippel M 1/2 BSP - M 3/8 NPS	Racor M 1/2 BSP - M 3/8 NPS	1
26	050 381 507	Tuyau Ø int. 10 (avec écrous 3/8 NPS)	Hose Ø 10 ID / 3/8 dia. (with nuts, 3/8 NPS)	Schlauch Ø 10 ID (mit Muttern 3/8 NPS)	Tubería Ø int. 10 (con tuercas 3/8 NPS)	1
34	905 210 305	Bouchon G 1/2"	Plug, G 1/2"	Blindstopfen, G 1/2"	Tapón, G 1/2"	1

➤ **Moteur / Motor, Mod. 1000-4 T & 2000-4 T**

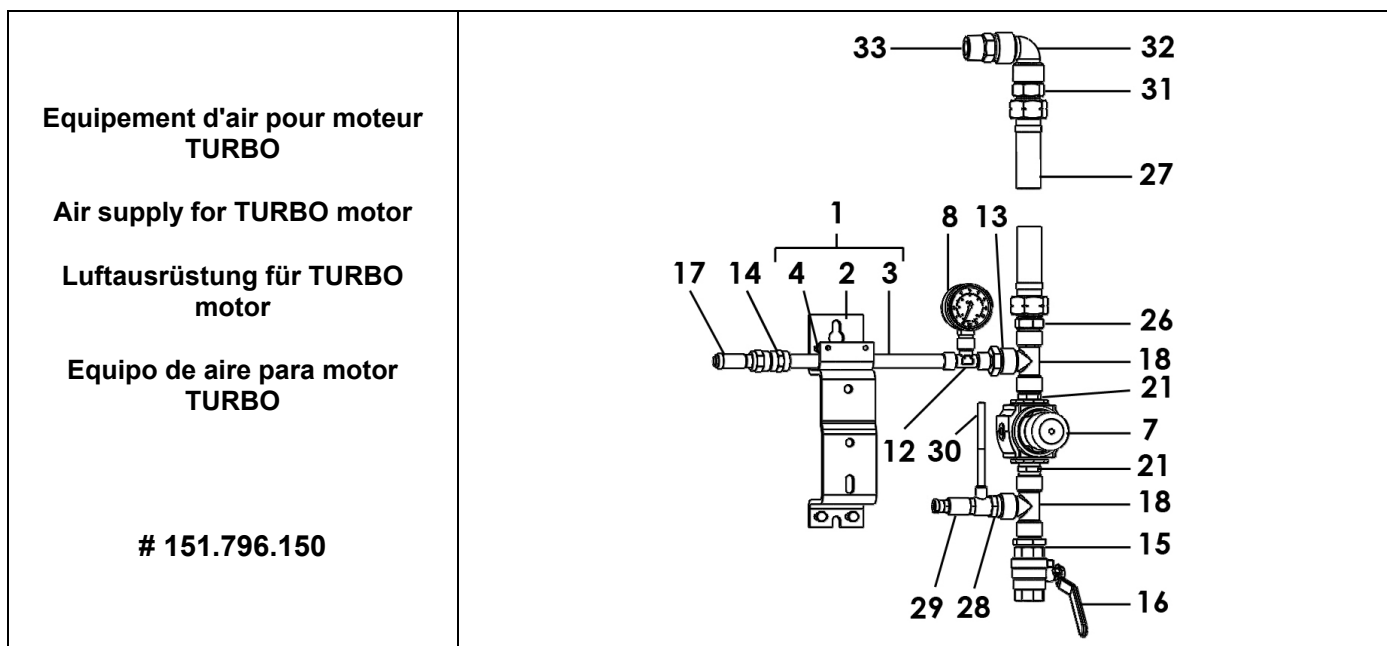

Pièces spécifiques - Specific parts - Spezifische Teile - Partes específicas

Ind	#	Désignation	Description	Bezeichnung	Denominación	Qté
26	050 102 401	Raccord M 1/2 BSP - M 3/4 NPS	Adaptor M 1/2 BSP - M 3/4 NPS	Nippel M 1/2 BSP - M 3/4 NPS	Racor M 1/2 BSP - M 3/4 NPS	1
27	050 383 104	Tuyau Ø int. 16 (avec écrous 3/4 NPS)	Hose Ø 16 ID / 3/8 dia. (with nuts, 3/4 NPS)	Schlauch Ø 16 ID (mit Muttern 3/4 NPS)	Tubería Ø int. 16 (con tuercas 3/4 NPS)	1
28	552 411	Réduction M 1/2" - F 1/4"	Adapter M 1/2" - F 1/4"	Reduziernippel AG 1/2" - IG 1/4"	Reducción M 1/2"- H 1/4"	1
*29	903 130 508	Régulateur de pression M 1/4 - T 4x6	Pressure regulator M 1/4 - T 4x6	Druckventil M 1/4 - T 4x6	Regulator de presión M 1/4 - T 4x6	1
30	050 371 001	Tuyau Ø 4 x 6 Lg : 1,2 m	Hose Ø 4 x 6 1.2 m long	Schlauch Ø 4 x 6 Länge : 1,2 m	Tubería Ø 4 x 6 1,2 m de largo	1
31	050 102 634	Raccord M 3/4 NPS - M 3/4 G	Fitting, double male, 3/4 NPS - 3/4 G	Doppelnippel, AG 3/4NPS - AG 3/4G	Racor, M 3/4 NPS - M 3/4G	1
32	552 429	Coude FF 3/4"	Elbow, FF 3/4"	Winkelnippel, IG 3/4"	Codo, HH 3/4"	1
33	050 102 215	Raccord MM 3/4"	Fitting, double male, 3/4"	Doppelnippel, AG 3/4 " - AG 3/4 "	Racor MM 3/4"	1

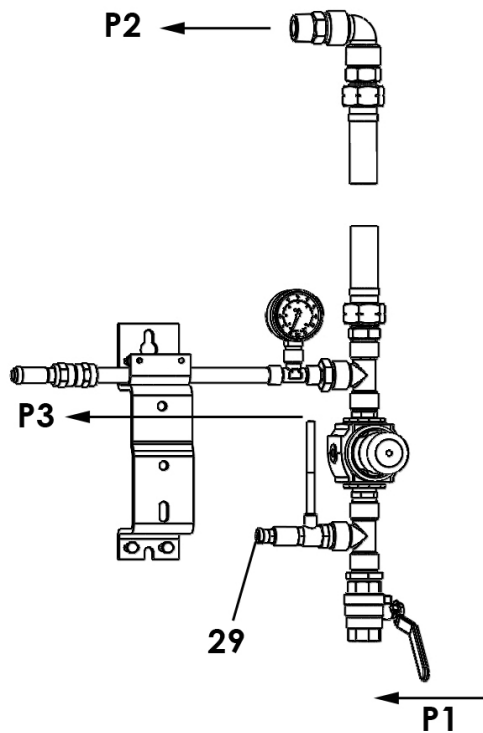

P1 = 6 bar max. / 87 psi

P2 = 1 → 5,5 bar / 14.5 → 80 psi
 (air de puissance / power air / Arbeitsluft / aire de potencia)

P3 = 4 bar max. / 58 psi max.
 (air de pilotage / pilot air / Steuerluft / aire de pilotaje)

Le régulateur (29) est pré réglé en usine pour délivrer une pression de 4 bar max.

The regulator (29) is preset in the factory to give a maximum pressure of 4 bar / 58 psi.

Der Druckregler (29) ist werksseitig auf einen maximalen Steuerluftdruck von 4 bar eingestellt.

El regulador (29) se regula en la fábrica para aportar una presión máxima de 4 bar.

* Pièces de maintenance préconisées.

* Preceding the index number denotes a suggested spare part.

* Bezeichnete Teile sind empfohlene Ersatzteile.

* Piezas de mantenimiento preventivas.

N C : Non commercialisé.

N S : Denotes parts are not serviceable.

N S : Bezeichnete Teile gibt es nicht einzeln, sondern nur komplett.

N S : no suministrado.

<p>Doc. 573.035.050 Date/Datum/Fecha : 24/03/21 Annule/Cancela/ Ersetzt/Anula : 05/11/18</p>	<p>Modif. / Änderung : Mise à jour / Update / Aktualisierung / Actualización</p>	<p>Pièces de rechange Spare parts list Ersatzteilliste Piezas de repuesto</p>
--	---	--

<p>DETENDEUR DE PULVERISATION</p>	<p>ATOMIZING AIR REGULATOR</p>	<p>#</p>
<p>ZERSTÄUBERLUFTSET</p>	<p>MANORREDUCTOR DE PULVERIZACIÓN</p>	<p>151.740.200</p>

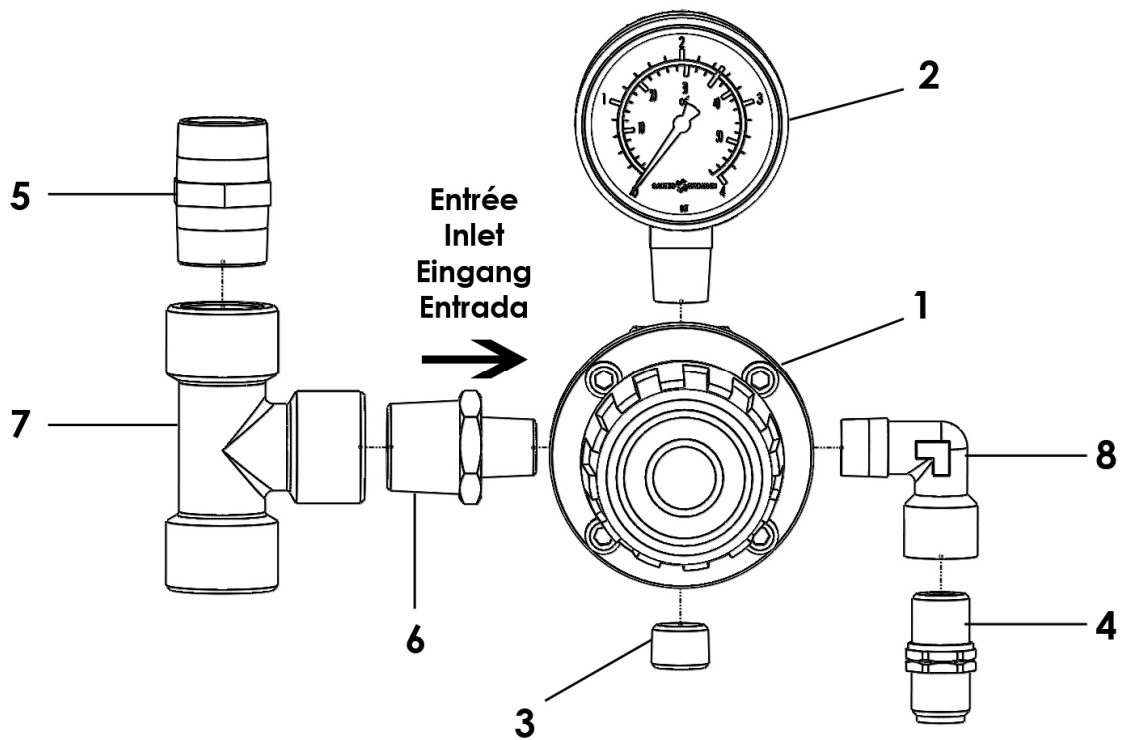
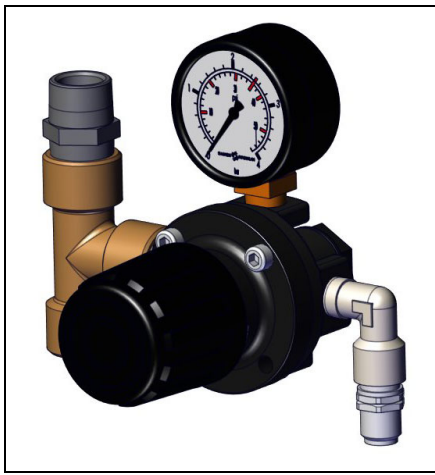

DETENDEUR DE PULVERISATION	ATOMIZING AIR REGULATOR	#
ZERSTÄUBERLUFTSET	MANORREDUCTOR DE PULVERIZACIÓN	151.740.300

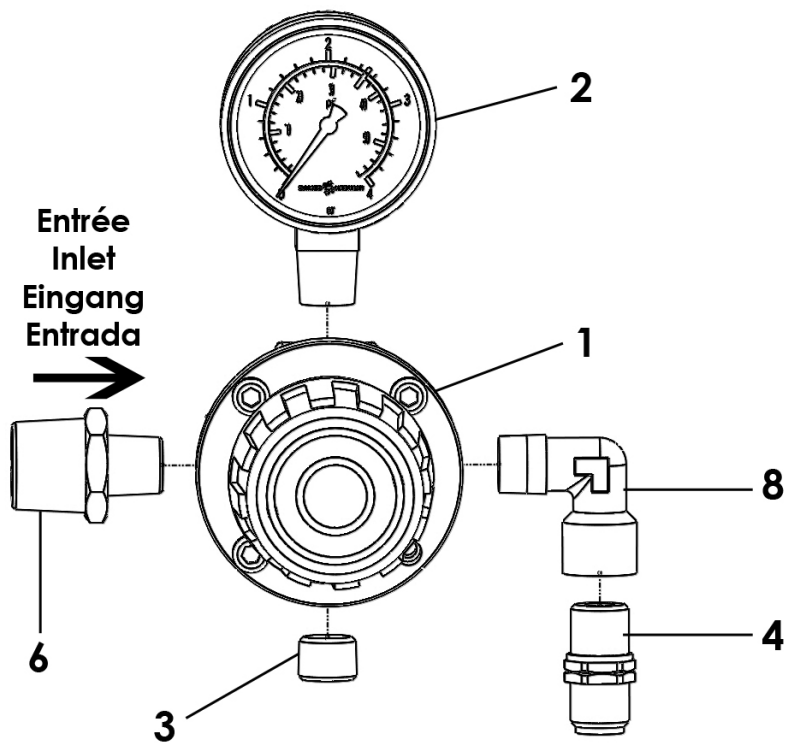

Pièces communes - Common parts - Gleiche Teile - Partes comunes

Ind	#	Désignation	Description	Bezeichnung	Denominación	Qté
1	016 380 500	Détendeur d'air 1/4 - 3,5 bar - volant noir (Doc. 573.288.040)	Air regulator, 1/4 - 3.5 bar / 51 psi - black knob (Doc. 573.288.040)	Druckminderer, 1/4 - 3,5 bar - Schwarz Stellglocke (Doc. 573.288.040)	Manorreductor, 1/4 - 3,5 bar - pomo de color negro (Doc. 573.288.040)	1
2	910 011 404	Manomètre 0 - 4 bar	Gauge, 0 - 4 bar / 0 - 58 psi	Manometer, 0 - 4 bar	Manómetro, 0 - 4 bar	1
3	906 333 102	Bouchon 1/4" G	Plug, 1/4" G	Blindstopfen, 1/4" G	Tapón, 1/4" G	1
4	050 102 624	Raccord M 1/4 BSP - M 1/4 NPS	Fitting, double male, 1/4 BSP - 1/4 NPS	Doppelnippel M 1/4 BSP - M 1/4 NPS	Racor, M 1/4 BSP - M 1/4 NPS	1
6	050 102 211	Raccord M 1/4 BSP - M 1/2 BSP	Fitting, double male, 1/4 BSP - 1/2 BSP	Doppelnippel, M 1/4 BSP - M 1/2 BSP	Racor, M 1/4 BSP - M 1/2 BSP	1
8	552 431	Coude MF 1/4"	Elbow, MF 1/4"	Winkelnippel, AG 1/4" - IG 1/4"	Codo, MH 1/4"	1

Pièces spécifiques - Specific parts - Spezifische Teile - Partes específicas # 151 740 200

Ind	#	Désignation	Description	Bezeichnung	Denominación	Qté
5	552 464	Mamelon MM 1/2"	Nipple, double male 1/2"	Rohnippel 1/2"	Pivote de centrado, MM 1/2"	1
7	552 438	Té FFF 1/2" BP	Tee, FFF 1/2" BP	T-Stück FFF 1/2" BP	Te HHH 1/2" BP	1

Le détendeur de pulvérisation se monte entre la vanne d'arrivée d'air et le détendeur d'alimentation moteur.

Le détendeur (1) permet l'alimentation en air d'un pistolet AIRMIX® par le raccord (4). La pression d'air de pulvérisation est lue sur le manomètre (2).

Il se monte :

- sur l'équipement d'air des pompes AIRMIX® (pompes équipées d'un moteur 1000/4 ou 2000/4),
- sur l'équipement d'air des pompes AIRLESS® de **rapport de pression 40 bar maxi**.

ATTENTION : monter un pistolet AIRMIX® adapté à la pression délivrée par la pompe.

The atomizing air regulator must be installed between the air inlet valve and the air motor supply regulator.

An AIRMIX® gun can be supplied with air by means of the regulator (1) and of an adaptor (4). The atomizing air pressure is read on the gauge (2).

It must be installed :

- on the air supply of the AIRMIX® pumps (equipped with an air motor, model 1000/4 or 2000/4),
- on the air supply of the AIRLESS pumps (**maximum pressure ratio 40 bar / 580 psi**).

CAUTION: install an AIRMIX® gun suitable for the pressure delivered by the pump.

Das Zerstäuberluftset wird zwischen dem Lufteingangshahn und dem Pumpenluftregler eingebaut.

Der Druckminderer (1) versorgt die AIRMIX® Pistole mit Luft mit Hilfe eines Doppelnippels (4). Der eingestellte Druck wird am Manometer (2) abgelesen.

Dieses Set wird montiert :

- auf die Luftausrüstung der AIRMIX® Pumpen (mit einem Motor 1000/4 oder 2000/4 ausgestatteten Pumpen),
- auf die Luftausrüstung der AIRLESS Pumpen mit **Druckübersetzung maximal 40 bar**.

ACHTUNG : eine AIRMIX® Pistole montieren, die dem Druck der Pumpe entspricht.

El manorreductor de pulverización se monta entre la válvula de llegada de aire y el manorreductor de alimentación motor.

El manorreductor (1) permite alimentar en aire una pistola AIRMIX® mediante el racor (4). La lectura de la presión de aire de pulverización se lleva a cabo mediante el manómetro (2).

El regulador se monta :

- en el equipo de aire de las bombas AIRMIX® (bombas equipadas con un motor, tipo 1000/4 o 2000/4),
- en el equipo de aire de las bombas AIRLESS con una **relación de presión 40 bar máxima**.

OJO : instalar una pistola AIRMIX® adaptada a la presión que aporta la bomba.

Doc. 573.299.050 Date/Datum/Fecha : 20/07/18 Annule/Cancela/ Ersetzt/Anula : 10/06/11	Modif. / Änderung : Mise à jour / Update / Aktualisierung / Actualización KREMLIN REXSON → SAMES KREMLIN	Pièces de rechange Spare parts list Ersatzteilliste Piezas de repuesto
---	---	--

FILTRE PRODUIT HP, modèle 3/8 inox	HP FLUID FILTER, model 3/8 stainless steel
HD MATERIALFILTER, Modell 3/8 Edelstahl	FILTRO PRODUCTO AP, tipo 3/8 inox

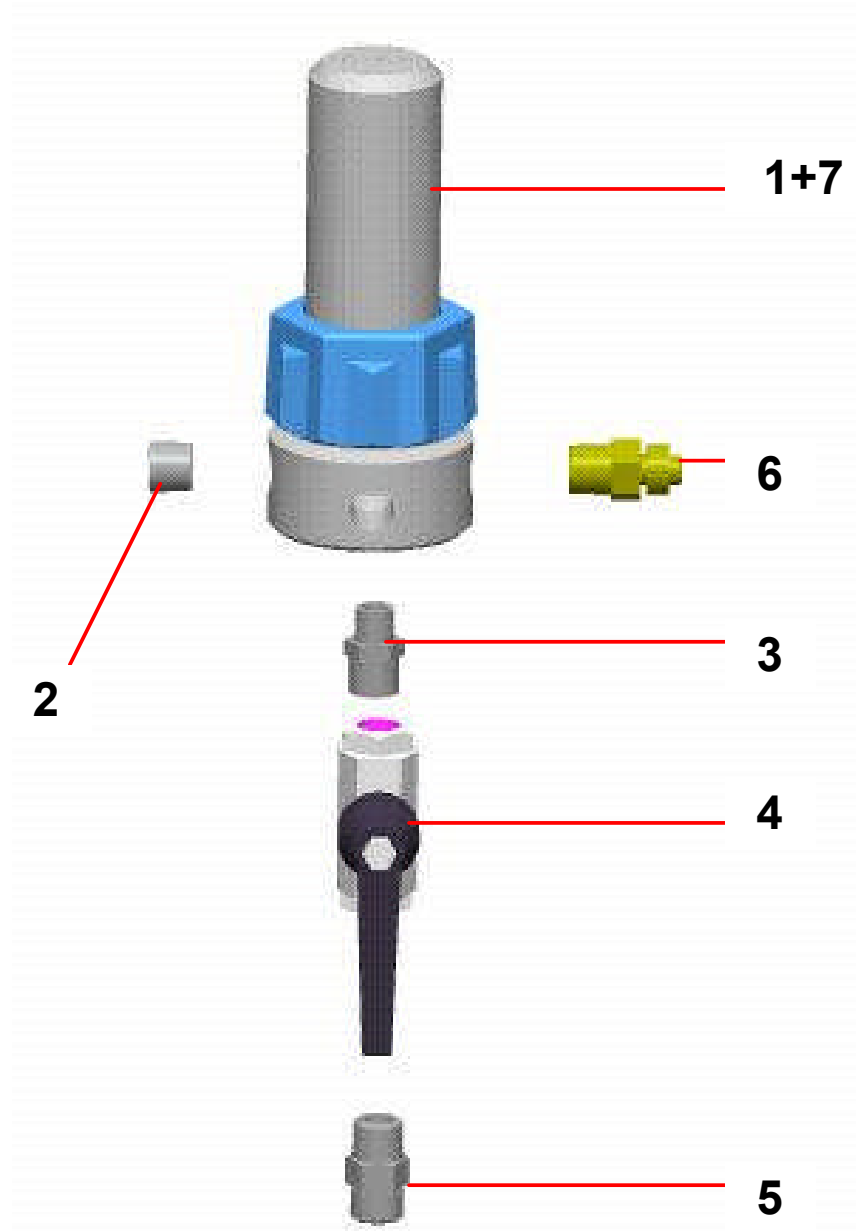

FILTRE EQUIPÉ pour pompes AIRMIX®	FILTRE EQUIPÉ pour pompes AIRLESS®
EQUIPPED FILTER for AIRMIX® pumps	EQUIPPED FILTER for AIRLESS pumps
AUSGERÜSTETER FILTER für AIRMIX®-Pumpen	AUSGERÜSTETER FILTER für AIRLESS®-Pumpen
FILTRO EQUIPADO para bombas AIRMIX®	FILTRO EQUIPADO para bombas AIRLESS®
# 155.580.300	# 155.580.400

PIECES COMMUNES - COMMON PARTS - GLEICHE TEILE - PARTES COMUNES

Ind	#	Désignation	Description	Bezeichnung	Denominación	Qté
*1	155 580 200	Filtre nu inox	Bare filter, stainless steel	Nackter Filter - Edelstahl	Filtro solo, inox	1
2	905 210 304	Bouchon inox 3/8 NPT	Plug , stainless steel 3/8 NPT	Blindstopfen - Edelstahl 3/8 NPT	Tapón de inox 3/8 NPT	1
3	906 314 204	Raccord inox M 1/4 - M 3/8	Fitting, double male, 1/4 - 3/8	Doppelnippel AG 1/4 - AG 3/8	Racor inox, M 1/4 - M 3/8	1
*4	000 750 040	Vanne HP FF 3/8 BSP	HP valve FF 3/8 BSP	Kugelhahn, IG 3/8 BSP	Válvula, AP 3/8 BSP	1
5	050 102 411	Raccord inox M 18 x 125 - M 3/8 BSP	Adaptor, stainless steel, double male 18x125 - 3/8BSP	Doppelnippel - Edelstahl AG 3/8 BSP - M 18x1,25	Racor inox, M 18 x 125 - M 3/8 BSP	1
6	905 210 503	Raccord inox M 3/8 NPT - M 1/2 JIC	Adaptor, stainless steel, double male, 3/8 NPT - # 5 JIC (1/2 JIC)	Doppelnippel Edelstahl 3/8 NPT - 1/2 JIC	Racor, inox M 3/8 NPT - M 1/2 JIC	1

PIECES SPECIFIQUES - SPECIFIC PARTS - SPEZIELLE TEILE - PARTES ESPECIFICAS

⇒ **Filtre / Filter / Filtro # 155.580.300**

Ind	#	Désignation	Description	Bezeichnung	Denominación	Qté
*7	000 161 106	Tamis n° 6 (168 µ)	Screen n° 6 (168 µ - 85 Mesh)	Filterelement Sieb Nr. 6 (168 µ)	Tamiz n° 6 (168 µ)	1

⇒ **Filtre / Filter / Filtro # 155.580.400**

Ind	#	Désignation	Description	Bezeichnung	Denominación	Qté
*7	000 161 112	Tamis n° 12 (280 µ)	Screen n° 12 (280 µ - 55 Mesh)	Filterelement Sieb Nr. 12 (280 µ)	Tamiz n° 12 (280 µ)	1

* Pièces de maintenance préconisées.

* Preceding the index number denotes a suggested spare part.

* Bezeichnete Teile sind empfohlene Ersatzteile.

* Piezas de mantenimiento preventivas.

FILTRE NU (sans tamis)	BARE FILTER (without screen)	#
NACKTER FILTER (ohne Sieb)	FILTRO SOLO (sin tamiz)	155.580.200

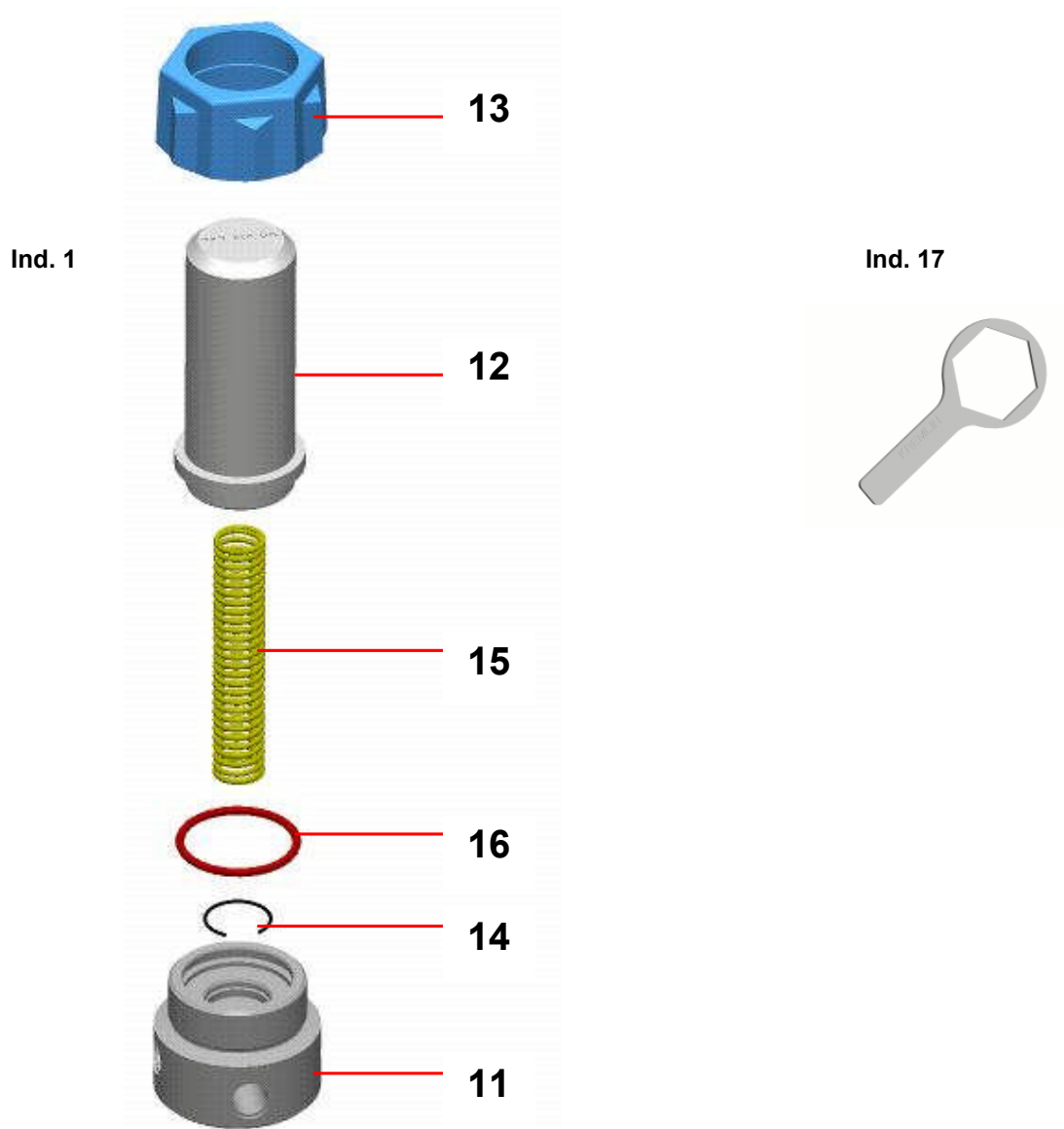

Ind	#	Désignation	Description	Bezeichnung	Denominación	Qté
11	055 580 201	Embbase 3/8	Base, model 3/8	Grundblock, Modell 3/8	Base, tipo 3/8	1
12	055 580 202	Cuve	Bowl	Filterglocke	Cubeta	1
13	055 280 002	Ecrou	Nut	Überwurfmutter	Tuerca	1
14	055 190 007	Jonc	Stop ring	Sicherungsring	Clips	1
15	055 190 005	Ressort	Spring	Feder	Muelle	1
*16	150 040 327	Joint (les 5)	Seal (pack of 5)	Dichtung (5 St.)	Junta (bolsa de 5)	1
17	049 030 018	Clé de démontage	Wrench	Schlüssel	Llave de desmontaje	1

A LA DEMANDE - ON REQUEST - AUF WUNSCH - A PETICIÓN

Ind. 7



Ind	#	Désignation	Description	Bezeichnung	Denominación	Qté
-	000 161 101	Tamis n° 1 (37 µ)	Screen n° 1 (37 µ)	Sieb Nr. 1 (37 µ)	Tamiz n° 1 (37µ)	1
-	000 161 102	Tamis n° 2 (77 µ)	Screen n° 2 (77 µ)	Sieb Nr. 2 (77 µ)	Tamiz n° 2 (77 µ)	1
-	000 161 104	Tamis n° 4 (99 µ)	Screen n° 4 (99 µ)	Sieb Nr. 4 (99 µ)	Tamiz n° 4 (99 µ)	1
7	000 161 106	Tamis n° 6 (168 µ)	Screen n° 6 (168 µ)	Sieb Nr. 6 (168 µ)	Tamiz n° 6 (168 µ)	1
-	000 161 108	Tamis n° 8 (210 µ)	Screen n° 8 (210 µ)	Sieb Nr. 8 (210 µ)	Tamiz n° 8 (210 µ)	1
7	000 161 112	Tamis n° 12 (280 µ)	Screen n° 12 (280 µ)	Sieb Nr. 12 (280 µ)	Tamiz n° 12 (280 µ)	1
-	000 161 115	Tamis n° 15 (360 µ)	Screen n° 15 (360 µ)	Sieb Nr. 15 (360 µ)	Tamiz n° 15 (360 µ)	1
-	000 161 020	Tamis n° 20 (510 µ)	Screen n° 20 (510 µ)	Sieb Nr. 20 (510 µ)	Tamiz n° 20 (510 µ)	1
-	000 161 030	Tamis n° 30 (750 µ)	Screen n° 30 (750 µ)	Sieb Nr. 30 (750 µ)	Tamiz n° 30 (750 µ)	1

OPTIONS - ON REQUEST - OPTIONEN - OPCIONES

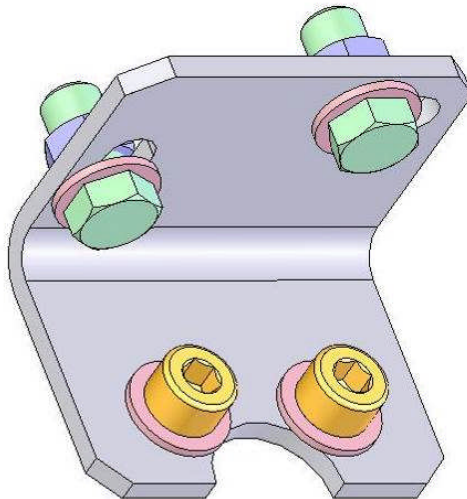

Ind	#	Désignation	Description	Bezeichnung	Denominación	Qté
-	155 190 105	Support filtre avec vis, rondelles et écrous	Mounting bracket with screws, washers and nuts	Filterhalterung mit Schrauben, Scheiben und Muttern	Soporte filtro con tornillos, arandelas y tuercas	1



**AIRMIX ® PUMP and
LOW-PRESSURE PUMP
air motor with reversing block
*PREVENTIVE MAINTENANCE***

TRANSLATION FROM THE ORIGINAL MANUAL

IMPORTANT : Before assembly and start-up, please read and clearly understand all the documents relating to this equipment (professional use only).

THE PICTURES AND DRAWINGS ARE NON CONTRACTUAL. WE RESERVE THE RIGHT TO MAKE CHANGES WITHOUT PRIOR NOTICE.

SAMES KREMLIN SAS
13, chemin de Malacher
38 240 - MEYLAN - France
☎ : 33 (0)4 76 41 60 60

www.sames-kremlin.com

■ PUMP

Make sure that the pump is clean and in good condition to increase equipment working life.

If the pump is an intensive™ one :

- Regularly clean the wetting-cup with "T" lubricant (this "T" lubricant will normally be coloured by the paint).
- Regularly clean the wetting-cup with solvent after having drained the lubricant (unscrew the plug on the upper flange).

**Guards (air motor cover, coupling shields, housings,...) have been designed for safe use of the equipment.
The manufacturer will not be held responsible for bodily injury or failure and / or damage to property due to removal or partial removal of the guards.**

Make sure that the suction strainer is clean and in good condition. Regularly clean it and change it if necessary.

Flush the pump as often as necessary, specially when spraying pigment-filled material.

**Whatever the case, when stopping the pump, always leave it filled with material.
For a short duration shutdown, if the flushing has not been carried out, leave the pump filled with material.
For a short duration shutdown, after flushing the pump, leave it filled with solvent.**

■ SPRAY GUN

Comply with the usual instructions of spray gun servicing (refer to spary gun instruction manual).

■ FILTER

If the pump is mounted with a filter at the fluid outlet, comply with the usual instructions of filter servicing (refer to filter instruction manual)



**AIRMIX ® PUMP and
LOW-PRESSURE PUMP
air motor with reversing block
*TROUBLESHOOTING***

TRANSLATION FROM THE ORIGINAL MANUAL

IMPORTANT : Before assembly and start-up, please read and clearly understand all the documents relating to this equipment (professional use only).

THE PICTURES AND DRAWINGS ARE NON CONTRACTUAL. WE RESERVE THE RIGHT TO MAKE CHANGES WITHOUT PRIOR NOTICE.

SAMES KREMLIN SAS
13, chemin de Malacher
38 240 - MEYLAN - France
☎ : 33 (0)4 76 41 60 60

www.sames-kremlin.com

CAUSE	SOLUTION
The pump does not start.	Check the pump air supply.
Priming trouble : → Air is always coming out from the spray gun. → Air (or material) does not come out from the spray gun.	Be sure that the spray gun is fully opened and air evacuated through this one. Air intake at the fitting or at the suction rod. Check the pump valves. If a valve is stucked by dry paint, it can be unsticked without disassembling it. Blow air pressure directly by suction fitting.
The pump does not stop at once when shutting off the spray gun : → The pump stops only on down stroke. → The pump stops only on up stroke.	Check exhaust valve or valve seal. Check suction valve or upper cartridge.
The pump does not reverse.	Check spring of the air motor reversing block. Lubricate reversing-block with HP 150 oil. Check is there is pilot air (depending on air motor model).
On intensive™ pump, the lubricant into the cup is fastly coloured.	Check the upper packing (tighten the cup or change seals if it is necessary).
On FLOWMAX ® pump, leakage of fluid at the bottom of the air motor.	Check bellow.
Spraying trouble.	Refer to spray gun instruction manual.
Decrease of material flow.	Refer to filter instruction manual.



**AIRMIX ® PUMP
and LOW-PRESSURE PUMP
air motor with reversing block
*OPERATING PRINCIPLE AND START-UP***

TRANSLATION FROM THE ORIGINAL MANUAL

IMPORTANT : Before assembly and start-up, please read and clearly understand all the documents relating to this equipment (professional use only).

THE PICTURES AND DRAWINGS ARE NON CONTRACTUAL. WE RESERVE THE RIGHT TO MAKE CHANGES WITHOUT PRIOR NOTICE.

SAMES KREMLIN SAS
13, chemin de Malacher
38 240 - MEYLAN - France
☎ : 33 (0)4 76 41 60 60

www.sames-kremlin.com

1. OPERATING PRINCIPLE

The pump (A) consists of :

- an alternating air motor (B),
- an hydraulic section (C) mechanically coupled to the air motor (B).

The air motor is supplied with compressed air by means of the regulator (D) (yellow/green knob). The pressure is read on the gauge (E).

During its alternating movement, the air motor drives the piston of the hydraulic section (C). The fluid is drawn in (L) and forced under pressure in (N). Due to its design, the pressure is always the one read on the gauge x pump ratio.

The spray air pressure of the gun is adjusted by means of the regulator (black knob) (F).

⇒ To adjust the fluid flow rate, turn the yellow/green knob (D) - (Gauge E).

⇒ To adjust the spray air, turn the black knob (F) - (Gauge G).

The pumps are intensive™ ones or Flowmax ® ones (with bellows).

2. START UP

2-1 FILLING

INTENSIVE™ PUMP

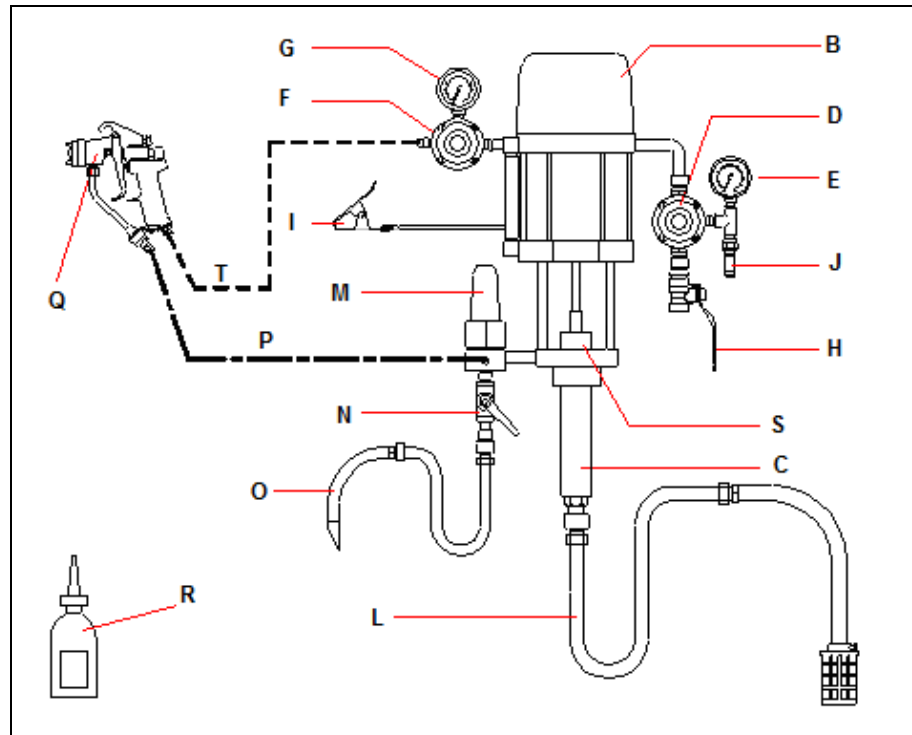

FLOWMAX® PUMP

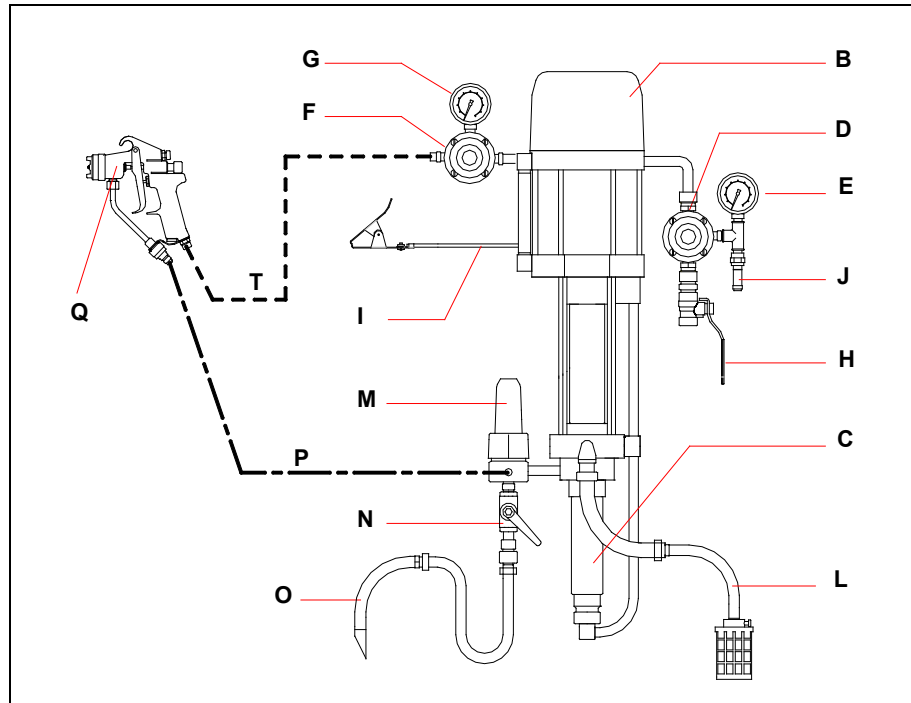

Captions :

A	Intensive™ or FLOWMAX® pump (B + C)	L	Suction rod (depending on version)
B	Air motor	M	Accumulator filter (depending on version)
C	Fluid section	N	Drain valve (depending on version)
D	Air regulator "MOTOR AIR"	O	Drain rod (depending on version)
E	Gauge	P	HP Fluid hose
F	Air regulator "GUN AIR" (depending on version)	Q	Spray gun
G	Gauge (depending on version)	R	"T" lubricant (1/4 l / 0.07 US gal) (only for intensive™ pump)
H	Air inlet valve	S	Wetting-cup (only for intensive™ pump)
I	Ground	T	Air hose (static conductor)
J	Discharge valve		

(For specific installation, please contact your SAMES KREMLIN representative).

Nota : If the pump is equipped with an accumulator filter (M), the filter is supplied with a stainless steel screen n° 6 (filtration size : 168 microns or 85 mesh). The screen is recommended for the use of an AIRMIX gun fitted with a nozzle model n° 6. If the fluid spraying is carried out by means of an other nozzle, choose an other screen (refer to the filter instruction manual). Adjust the screen to the application.

Start up procedure :

- 1 - Ground the pump.
- 2 - **If the pump is a intensive™ one, fill up the wetting-cup (S) with "T" lubricant (R) or with an appropriate solvent.**
- 3 - Unscrew the air regulators (D and F).
- 4 - Interconnect the air equipment with the air pressure network (clean air - Pressure < 6 bar / 87 psi). Install a water drop, model 3/4" (or model 3/8" if the pump is equipped with an air motor, model 500/4), if it is necessary.
- 5 - Connect all the hoses, air hose and fluid hose (P), as well as the spray gun (Q).
Nota : Comply with the diameters of hoses recommended in the specifications of the pump.
- 6 - Remove the nozzle from the spray gun.

■ **FLUSHING WITH SOLVENT**

- 7 - Immerse suction rod (L) and the drain rod (O) into the material container.
- 8 - Open the air shut off valve (N).
- 9 - Open the valve (H) of the pump air equipment to supply the air motor.

Nota : If the pump air motor is a 5000 version, it needs pilot air to operate. The pump air equipment supplies pilot air to the air motor. The air supply pressure is adjusted previously in the factory to 4 bar / 58 psi maximum.

- 10 - Increase **progressively** the air regulator (D) so that the pump runs slowly (Pressure between 0.5 to 1 bar / 7.25 to 14.503 psi).
- 11 - Observe the drain (O); air bubbles come out from it. When bubbles no longer come out from it, shut off the drain valve (N).

■ **PRIMING WITH MATERIAL**

- 12 - Remove the suction rod (L) and the drain rod (O) from the material container and immerse them in a solvent filled container.
- 13 - Open the drain valve (N), wait until the material flows out regularly, then shut off the drain valve (N).
- 14 - Point the spray gun towards the material container and trigger the spray gun until the material flows out regularly.

■ **WORK**

- 15 - Reinstall the ring and the aircap on the spray gun.
- 16 - Adjust air regulator (D) to obtain the appropriate material pressure and flow rate.
- 17 - **Gradually** open the air regulator (F) to adjust the spraying air to obtain the required spray pattern.

Nota : Some of these pumps are not equipped in the intensive™ version with the air regulator (F).

A spraying air kit can be mounted on the pump air equipment in order to supply compressed air to the spray gun if it is necessary.

2-2 PUMP SUPPLIED IN FILLING (CIRCULATING)

Interconnect the pump fluid inlet with the circulating supply hose and start up the pump as it is specified previously.

If the pump is a FLOWMAX® one :

WARNING:

- **Fluid section filling pressure** : 2 bar / 29 psi maximum
- **WARNING : Do not create overpressure**
- **NEVER use** the pump when **an isolating gate on the supply circuit** (upstream from the FLOWMAX® fluid section) is shut : **it would damage the bellows.**
- **Do not install** a material regulator on the supply circuit or any arrangement that could perform as a non-return valve.

3. SHUTDOWN AT THE END OF THE WORK

▪ SHORT DURATION SHUTDOWN

- 1 - Decrease the material pressure of air regulator (D) until reading **0 bar / 0 psi** on the gauge (E).
- 2 - Trigger the spray gun to depressurize the system.
- 3 - Unscrew the spray gun air regulator (F) or disconnect the spray gun air inlet.
- 4 - Remove the aircap from the spray gun, (aircap and nozzle for Airmix ® spray gun) and soak it into solvent.

▪ LONG DURATION SHUTDOWN

- 1 - Decrease the air regulator (D) until reading **1 bar / 14.503 psi** on gauge (E).
- 2 - Unscrew the spray gun air regulator (F) or disconnect the spray gun air inlet.
- 3 - Remove the spray gun aircap, (aircap and nozzle for AIRMIX ® spray gun) and soak it into solvent.
- 4 - Open the drain valve. The pump must operate slowly. If the speed is too high, decrease the air regulator (D) pressure.
- 5 - Remove the suction rod and the drain rod from the material container and immerse them in a solvent-filled container. Take all the appropriate precautions in the presence of flammable solvents.
- 6 - When the solvent flows out regularly, close the drain valve.
- 7 - Point the spray gun towards the material container and press the gun trigger. When the solvent flows out, point the spray gun towards the recovery container.
- 8 - When the solvent flows out, release the spray gun trigger.
Nota : If the pump is a intensive™ one, release the spray gun trigger when the pump is in a low position. To prevent from damaging the seals when starting the pump, the piston must be immersed into solvent.
- 9 - Fully unscrew the air regulator (D) and shut off the main compressed air valve (valve H).
- 10 - Press the spray gun trigger to decompress the hoses. Therefore, the pump and the hose remain filled with solvent at the atmospheric pressure

4. SAFETY DEVICE

Guards (air motor cover, coupling shields, housings ...) have been designed for safe use of the equipment.

The manufacturer will not be held responsible for bodily injury or failure and / or damage to property due to removal or partial removal of the guards

A relief-valve (setting : 6.5 bar / 94 psi) is fitted on the pump air motor - thus protecting this one from an overpressure which could damage it.



STAINLESS STEEL AIRMIX® PUMPS

20C100
20C100 T

TECHNICAL FEATURES

TRANSLATION FROM THE ORIGINAL MANUAL

IMPORTANT : Before assembly and start-up, please read and clearly understand all the documents relating to this equipment (professional use only).

THE PICTURES AND DRAWINGS ARE NON CONTRACTUAL. WE RESERVE THE RIGHT TO MAKE CHANGES WITHOUT PRIOR NOTICE.

SAMES KREMLIN SAS
13, chemin de Malacher
38 240 - MEYLAN - France
☎ : 33 (0)4 76 41 60 60
www.sames-kremlin.com

1. DESCRIPTION

- Stainless steel pump
- Low maintenance and ease of use

Recommended for :

- Supplying one or several spray guns
- Water-based or solvent-based paints whose viscosity is lower than 1000 mPa/s

2. TECHNICAL FEATURES

Motor type1000-4 or 1000-4T
 Pump body fluidC100
 Theoretical pressure ratio 20/1

Wetted parts :

Hard chrome stainless steel,
 stainless steel,
 carbide.

Tightness packings :

Upper, fixed : Polyfluid + PTFE G + PU
 Lower, mobile : GT

Air motor stroke	100 mm	4"
Air motor section	100 cm ²	15.5 sq.in
Hydraulic section	5 cm ²	0.8 sq.in
Delivery per cycle	100 cc	3.5 oz
Number of cycle	10 per liter	38 per gal
Fluid delivery (30 cycles)	3 l	0.8 USgal
Maximum air operating pressure	6 bar	88 psi
Maximum discharge pressure	120 bar	1 740 psi
Weighted sound pressure (LAeq)	79,3 dBa*	79,3 dBa*
	60° C	140° F
Maximum operating temperature	22 kg	49 Lbs
Weight		

* Test conditions - Noise level :

- Test duration : 30 s,
- Motor air pressure : 6 bar,
- Material used : water,
- Flow rate : Pump adjusted at 20 cycles/minute

■ FITTINGS

		Bare pump	Pump with equipment
Air	Inlet	1000-4 air motor : F 3/8 BSP 1000-4T air motor : M 3/4 NPS	F 3/8 BSP (air supply)
Material	Inlet	F 1/2 BSP	M 26 x 125 + suction rod (fitting F 26 x 125)
	Outlet	F 3/8 NPS	M 1/2 JIC / # 5 JIC (filter outlet)

■ HOSES WITH FITTINGS

Pump air supply hose (minimum \varnothing for a 5 m / 16.5 ft length) : \varnothing 16 mm / 5/8"
 Air hose (between "GUN AIR" regulator and gun) : \varnothing 7 mm ID / 1/4 dia.
 AIRMIX® fluid hose (between pump fluid outlet and spray gun) : \varnothing 4.8 mm int. / 3/16"

▪ DIMENSIONS

Ind.	mm	"	Ind	mm	"	Ind	mm	"	Ind	mm	"
A	288	113.3	B	262	103	C	182	71.6	D	821	323.2
E	482	189.7	F	Ø 196	Ø 77						

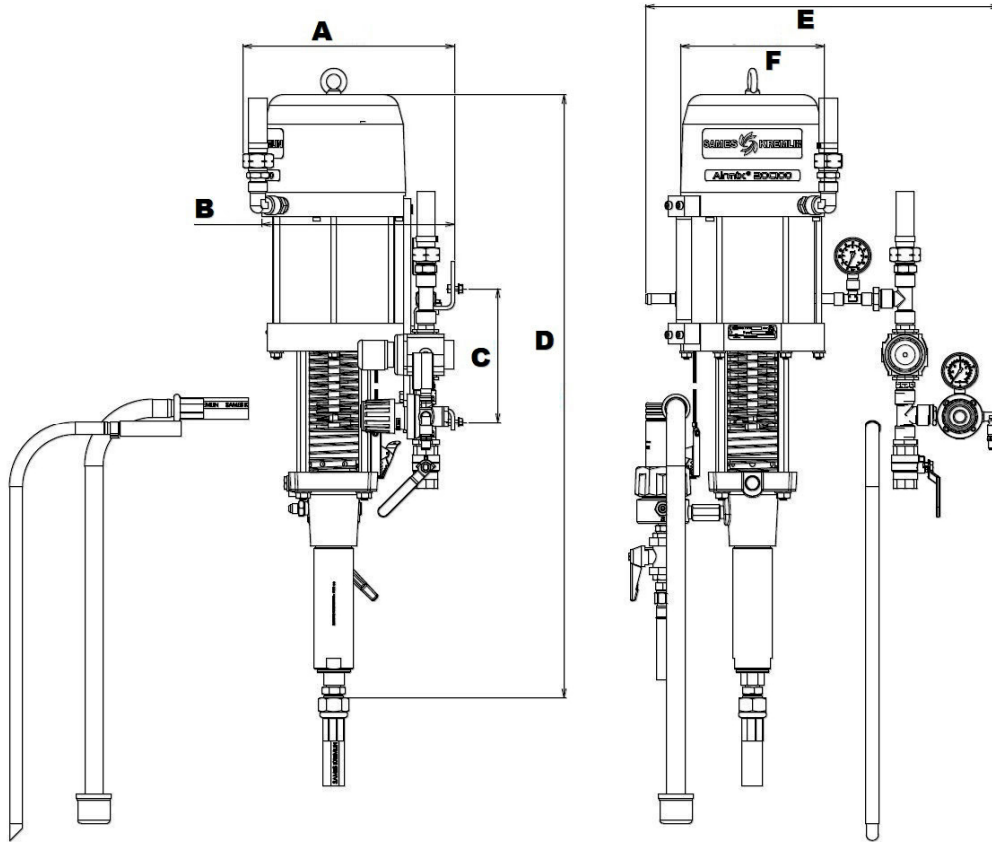

3. INSTALLATION

The pumps are designed to be installed in a spray booth.

▪ **DESCRIPTION OF THE LABEL MARKING**

Marking in accordance with the ATEX regulation

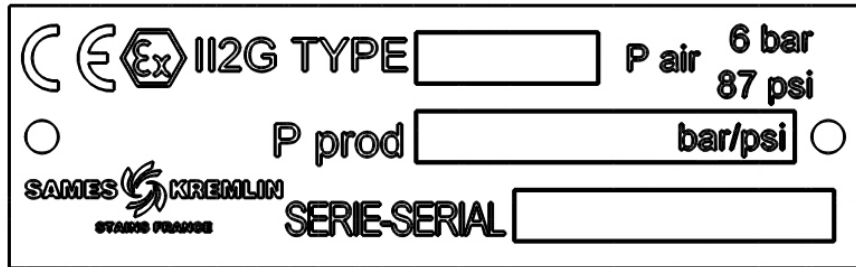

SAMES KREMLIN STAINS FRANCE	Name and address of the manufacturer
TYPE xx	Pump model
CE II 2 G	CE : European conformity : For use in explosive area II : group II 2 : class 2 G : gas Surface equipment meant to an area where explosive atmospheres due to gas, vapours, mists are liable to appear from time to time in usual operating.
P prod : xx bar / xx psi	Maximum fluid pressure at the pump outlet
P air : 6 bar / 87 psi	Air supply maximum pressure of the pump motor
Serie / Serial	Number given by SAMES KREMLIN. The 2 first numbers indicate the manufacturing year.

▪ **TEMPERATURE CLASS**

Pump, model 20C100:

Temperature class	Maximum surface temperature
T1	316.8° C / 602.2°F

Pump, model 20C100 T :

Temperature class	Maximum surface temperature
T1	312.1°C / 593.78°F

■ INSTALLATION DIAGRAM

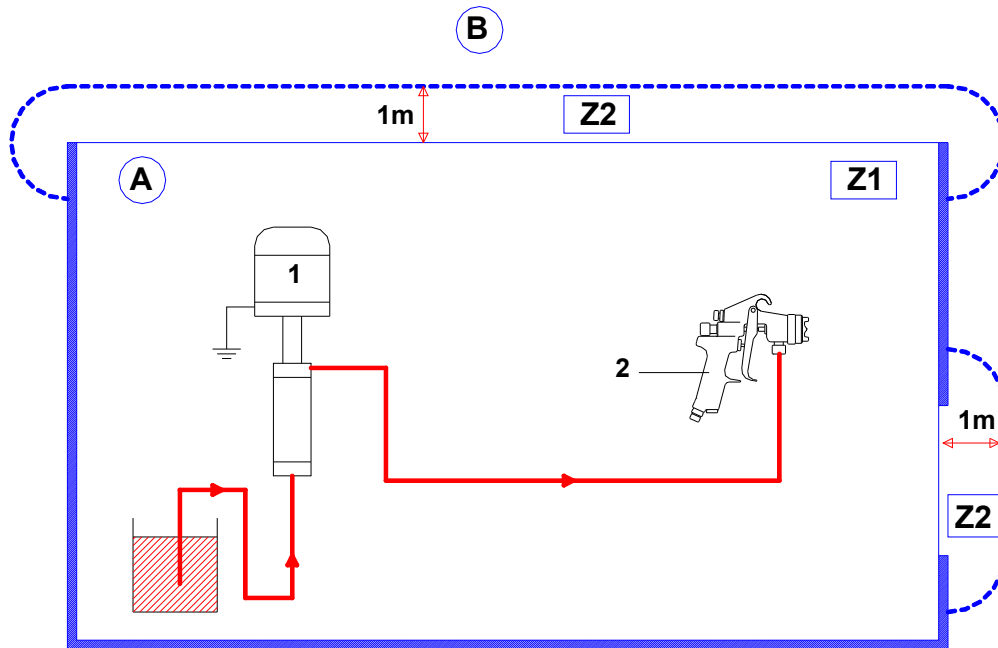

Ind.	Description
A	Explosive area area 1 (Z1) or area 2 (Z2) : spray booth
B	Non explosive area

Ind.	Description
1	Pump
2	Spray gun



The 1 m / 39.37" distance indicated in these diagrams is given for information purposes only and hold harmless to SAMES KREMLIN. The user is responsible for the extraction and conditioning of the painting area where the equipment is used, for working conditions (refer to EN 60079-10 standard). The 1 m / 39.37" distance may be modified if trials carried out by the user deem this necessary.



NB : Choose the appropriate pump to ensure that the working pressure supplied is suitable for the selected gun.